

WORK IN PROGRESS!!

*Bae*  
**TEMPEST**  
*Parkjet*



6th Generation Jet Fighter

**Construction Guide**

© 2018 Craig Clarkstone. All rights reserved

# Tempest History

Tempest is a proposed stealth fighter aircraft concept to be designed and manufactured in the United Kingdom for the Royal Air Force. It is being developed by a consortium known as "Team Tempest" consisting of the UK Ministry of Defence, BAE Systems, Rolls-Royce, Leonardo S.p.A. and MBDA, and is intended to enter service from 2035 replacing the Eurofighter Typhoon aircraft in service with the RAF. £2 billion (approximately \$2.66 billion) will be spent by the British government on the project by 2025.

The RAF had a similarly named fighter in the Second World War which also followed a Typhoon.

Announced by the British Defence Secretary Gavin Williamson on 16 July 2018 at the Farnborough Airshow as part of the Combat Air Strategy. Tempest will be a sixth-generation jet fighter incorporating several new technologies.

- Tempest will be able to fly unmanned,
- use swarming technology to control drones.
- It will incorporate artificial intelligence deep learning
- possess directed-energy weapons.
- Another piece of technology being designed into Tempest is Cooperative Engagement Capability, the ability to cooperate on the battlefield, sharing sensor data and messages to coordinate attack or defence.
- Tempest will feature an adaptive cycle engine and a virtual cockpit shown on a pilot's helmet-mounted display.



## Designers Notes



[www.maf-uk.org/](http://www.maf-uk.org/)

All donations given will be passed on to the charity M.A.F donation for \$10 to Paypal address :-  
clicketyclarkstone@gmail.com  
please quote 'Jetworks MAF donation'

Photo's used in this manual are copyright of their respective owners.

© 2017 Craig Clarkstone. All rights reserved. The design is free for non-commercial use only.

# TEMPEST

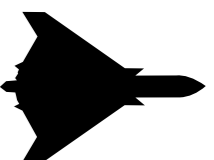

# Before you start.



## Adhesives

- > For the majority of construction :
  - UHU Creativ for Styrofoam (also called UHU POR)
  - 3M 77 Spray adhesive.
- > For wing spars and motor mounts :
  - Epoxy. (5 and 15mins cure times are the most convenient) micro-balloons can be added to reduce weight.
- > For servo's / and quick grab :
  - Hot melt glue gun - Caution if the glue gets too hot it will melt foam - test first!

## Tapes

- > For holding parts tightly together whilst glue sets
  - Low tack masking tapes
- > For leading edges, hinges, general strengthening
  - 3M Gift tape (Purple - not green one!) - I prefer lightweight plastic hinges.

## Cutting parts

1. Print the plans,
  2. Cut around each part using scissors - allow a border of approx (1/4") 6mm
  3. Use either 3M spray mount or a very light coat of 3M 77 to the back of the parts and stick in an economical layout on the Depron foam.
  4. Using a safety rule and craft knife over a cutting mat - important! use a fresh blade otherwise it will drag and spoil the foam. (I find the stanley knife perfect) make the straight edge cuts, then the curved parts freehand.
  5. Once the parts are cut-out, keep the template stuck to the part until just before needed to help identify the parts.
  6. After use, I find it helpful to keep all the used tempates in case replacement parts need making. (the glue eventually dries and they don't stick together!)
- IMPORTANT** Wherever the plans call for marking guidelines onto the depron, please ensure that you do otherwise it can cause problems later on. I suggest you use a Sharpie Fineliner to transfer the lines.

## Glueing parts together.

1. Ensure a really good fit - this will reduce the amount of adhesive used. The Bar Sander is a great tool for this.
2. Follow the adhesive instructions closely.
3. Use ordinary steel head pins to help keep the parts located whilst epoxy sets.
4. Use objects as weights such as paperweights to apply pressure whilst adhesive sets.
5. Use masking tape to apply pressure whilst adhesive sets. Also use masking tape to along the slots for the wing spars whilst gluing the carbon rod spars into the wings. This prevents the glue protruding and gives a nice finish.

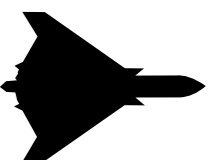

EDF only

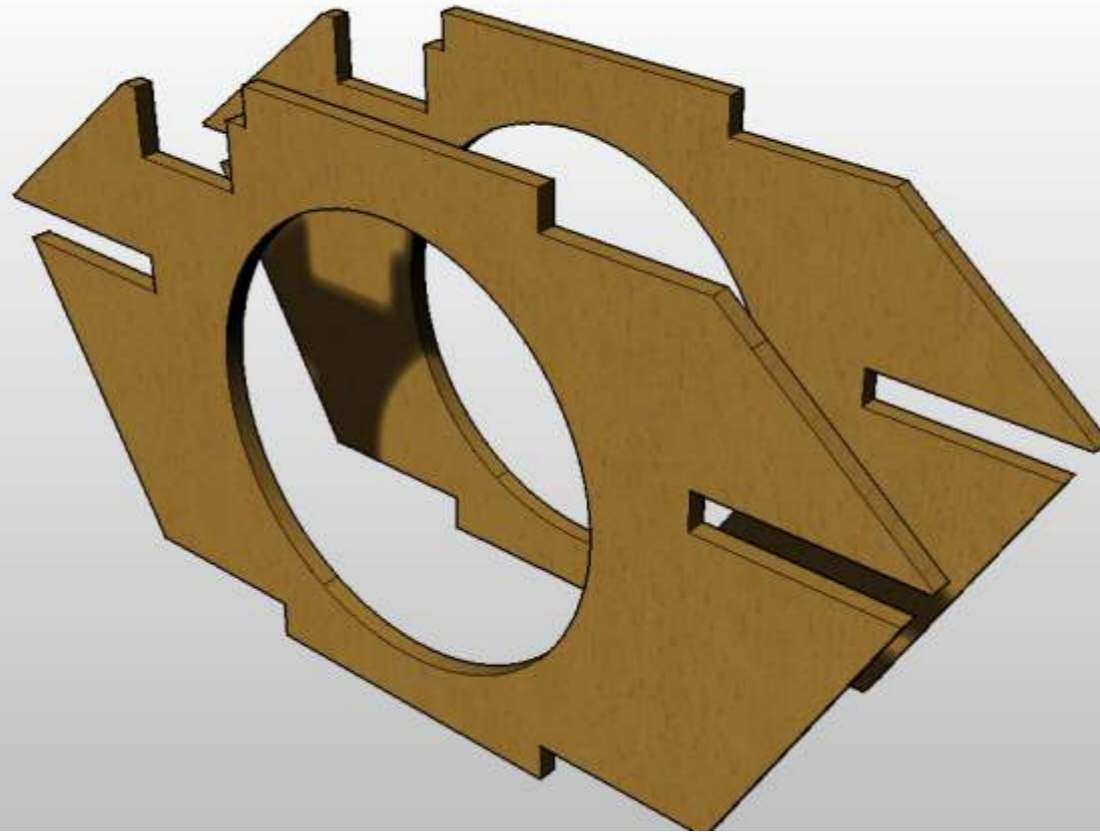

Before you cut out the liteply, ensure that the circular aperture matches your chosen EDF. This design can take a 64-70mm EDF unit.

Glue the two 3mm liteply EDF bulkheads together using epoxy.

Using the depron wing shape as a reference, cut the carbon tubes to shape, with an angled end to match the angle of the other carbon spars. If they are a few mm too long, they can be sanded down to length.

Lie the assembly down while gluing using masking tape to contain the epoxy in the slots. Ensure that the carbon tubes are completely horizontal using a straight edge.

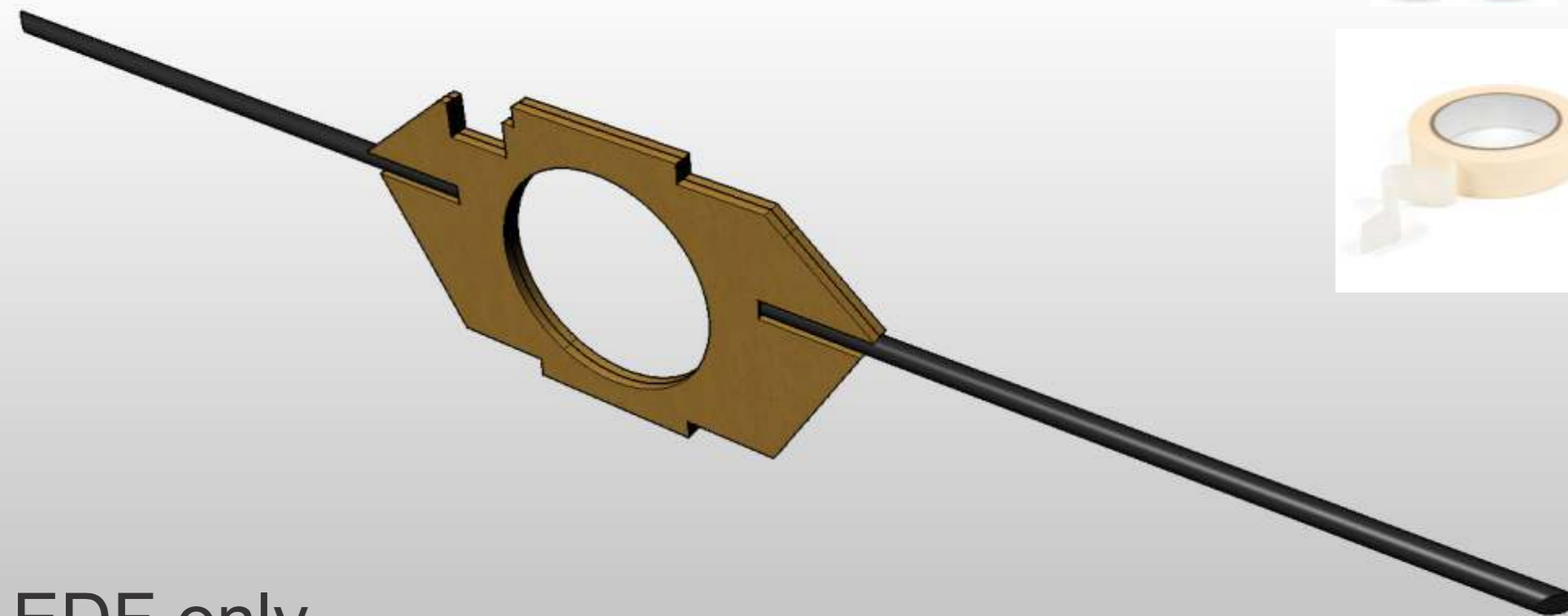

EDF only

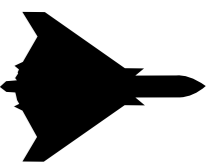

# Pusher only

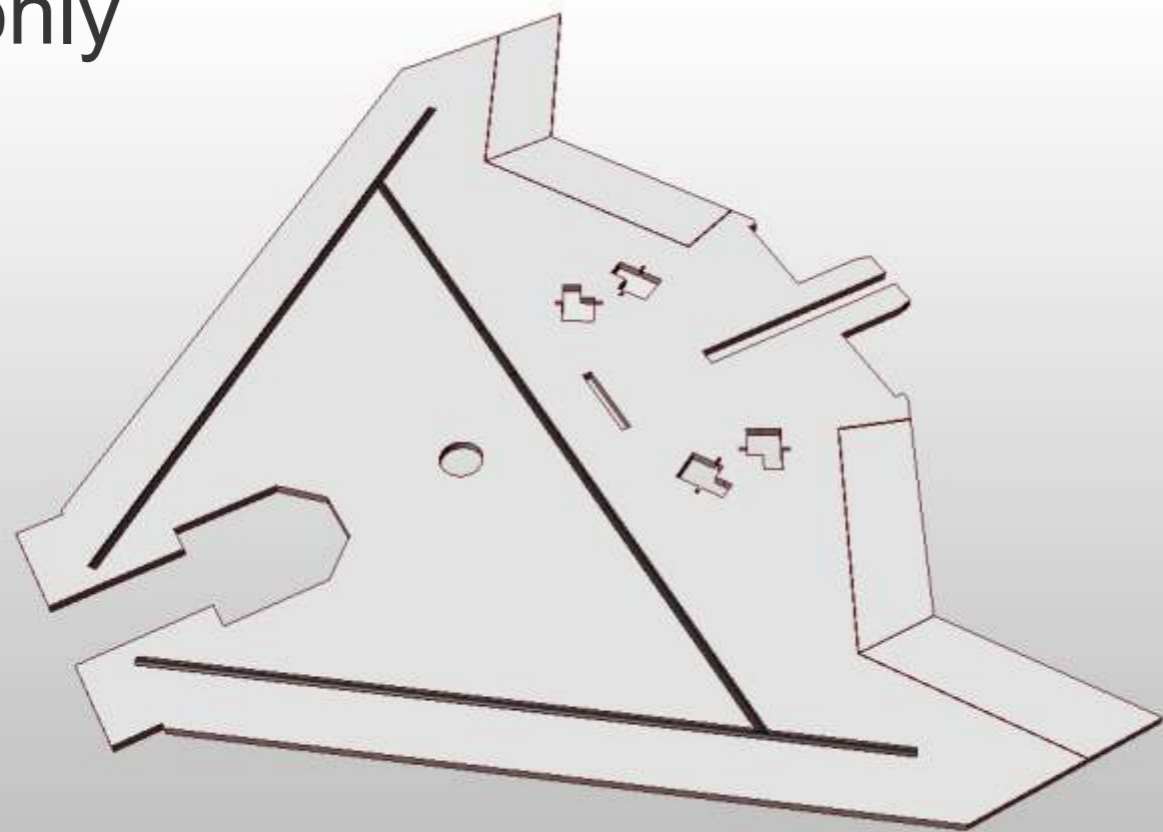

Using masking tape to prevent spillage, glue the carbon spar into the wing.

Put masking tape over the top of the joint and lay in a flat place, preferably with a weighted object such as a book to keep it flat while the glue sets.

# EDF only

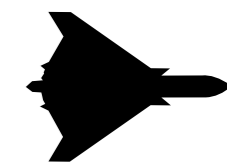
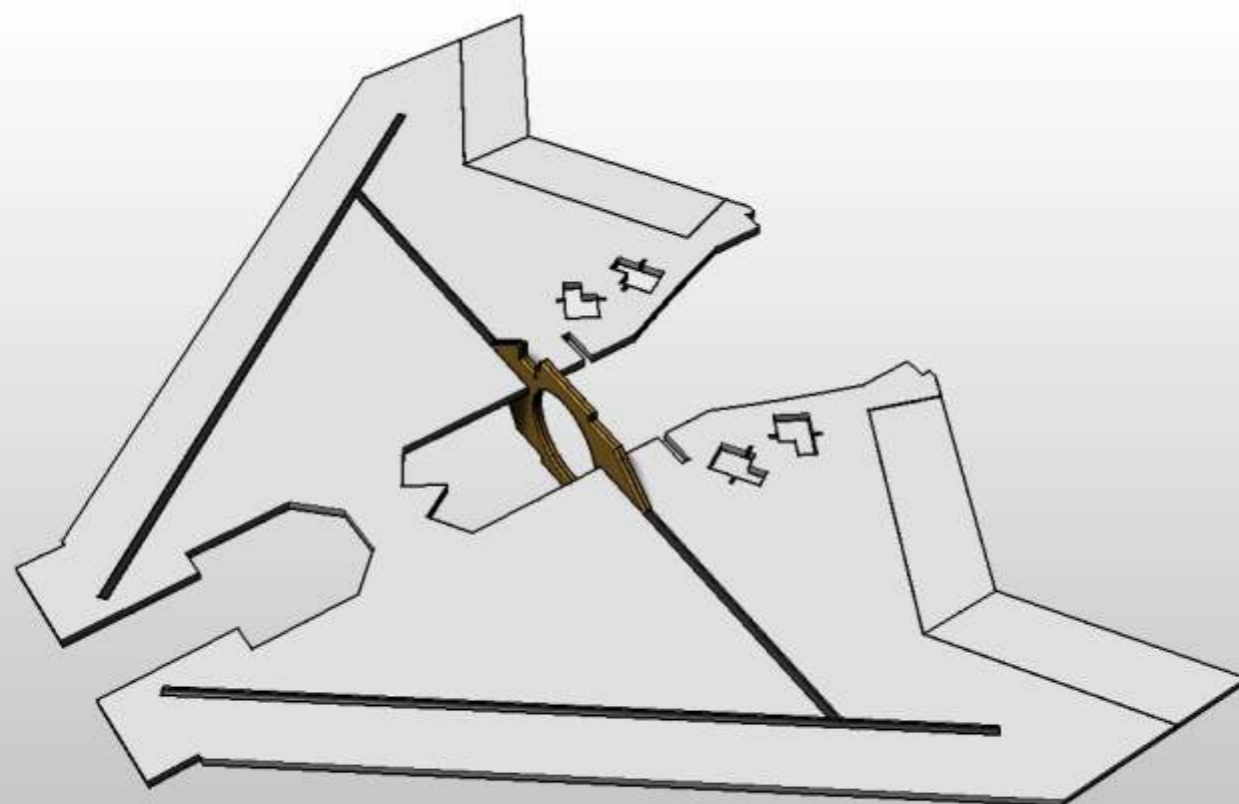

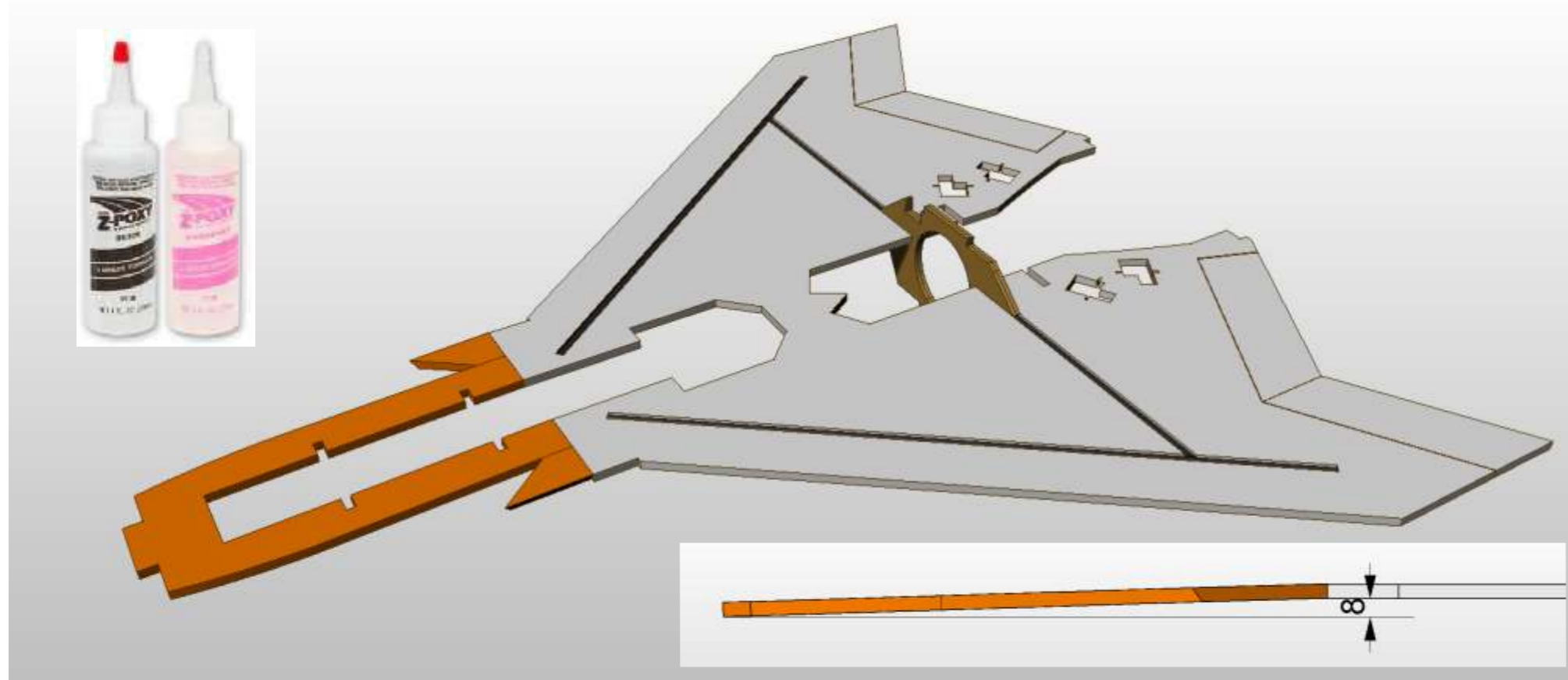

Glue the forward fuselage former to the wing, ensuring that it is slightly nose-down by 8mm as shown in the diagram below.

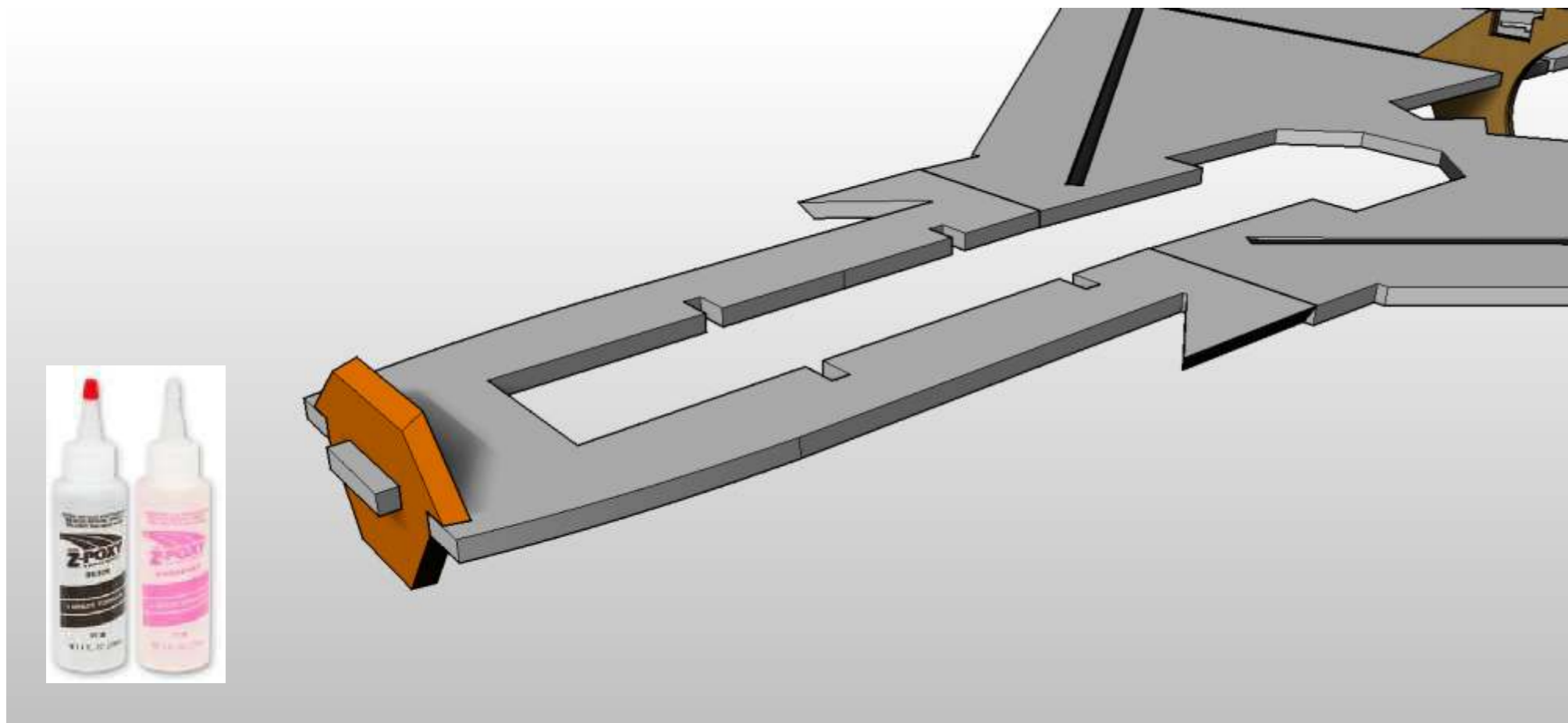

Glue bulkhead 1 in place.

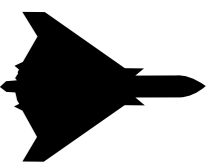

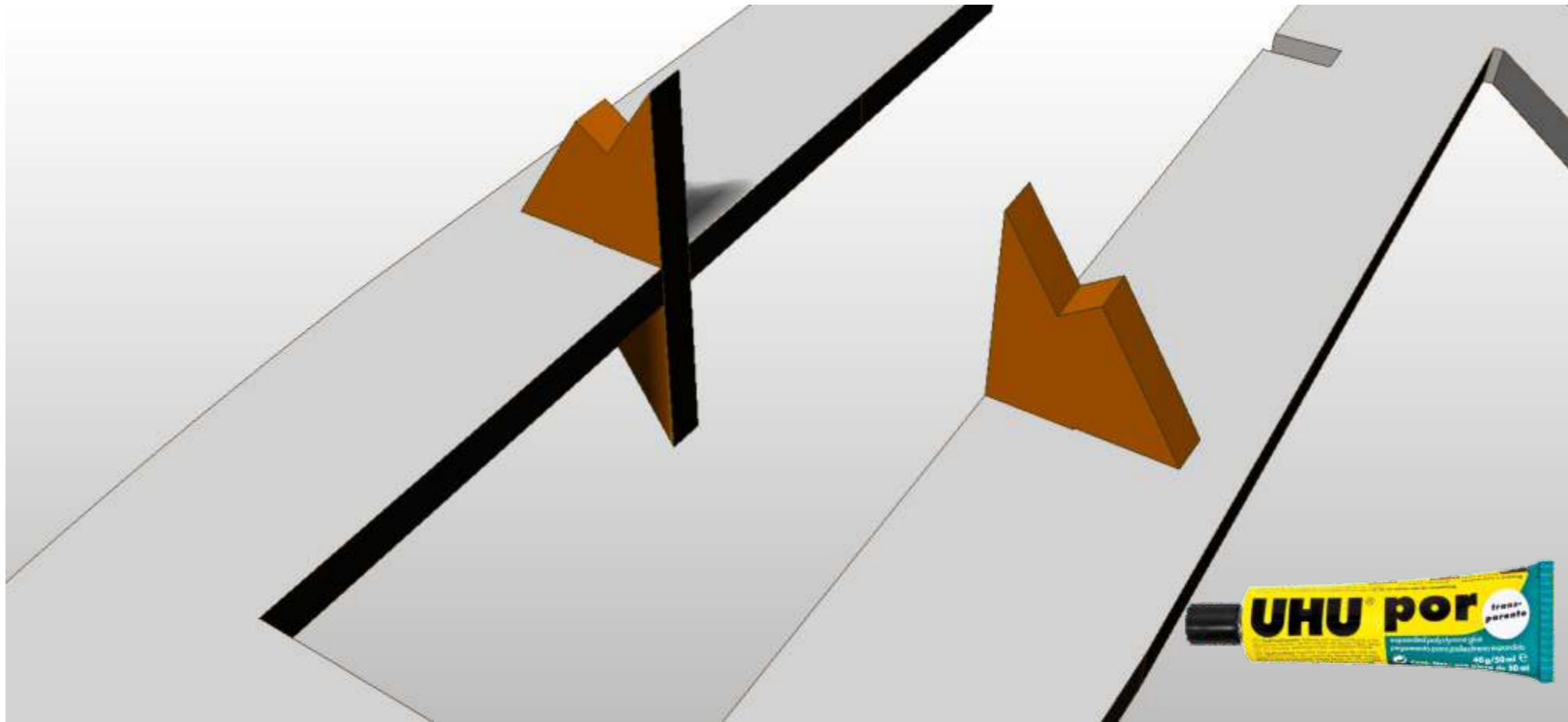

Glue the two pieces of Bulkhead 2 to the assembly.

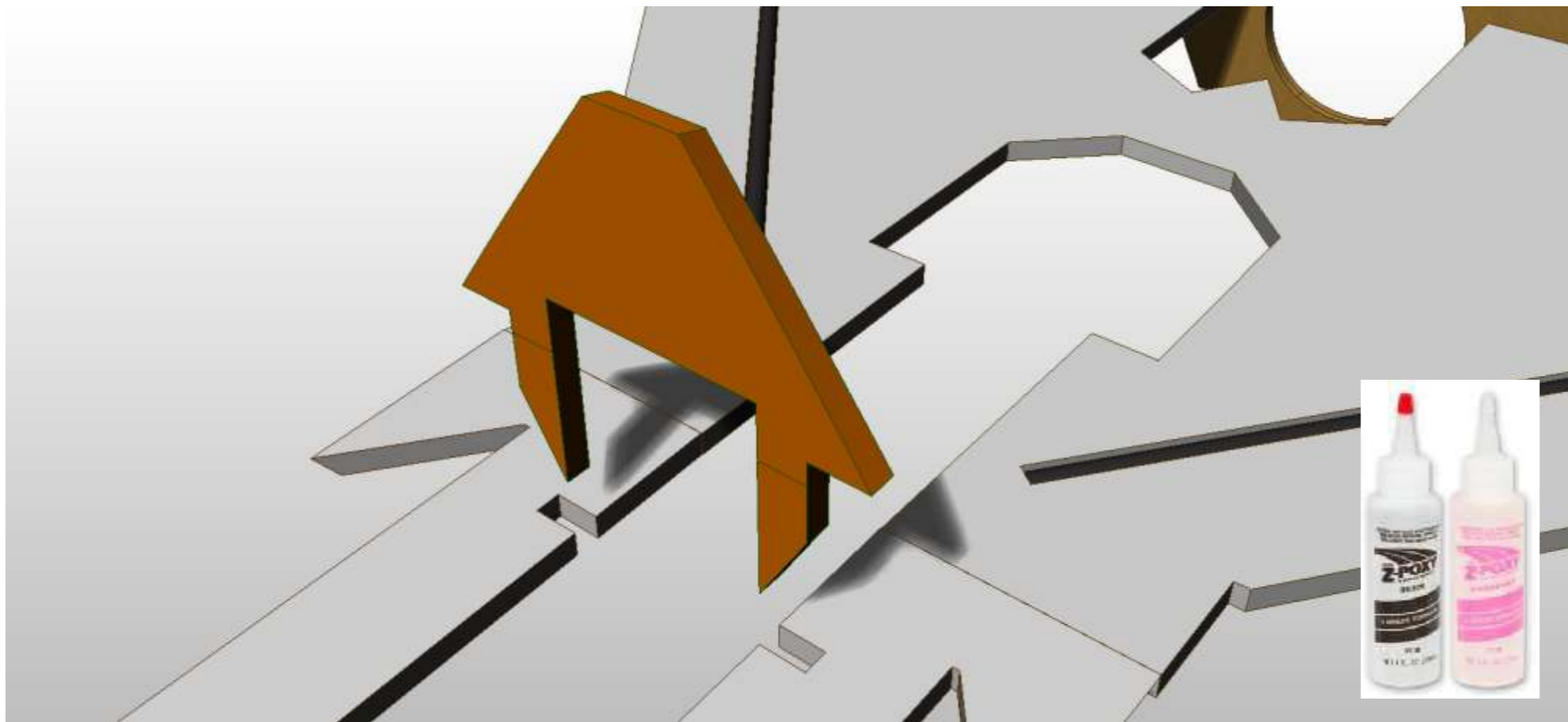

Glue bulkhead 3 in place

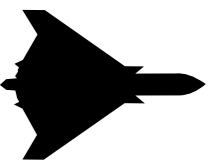

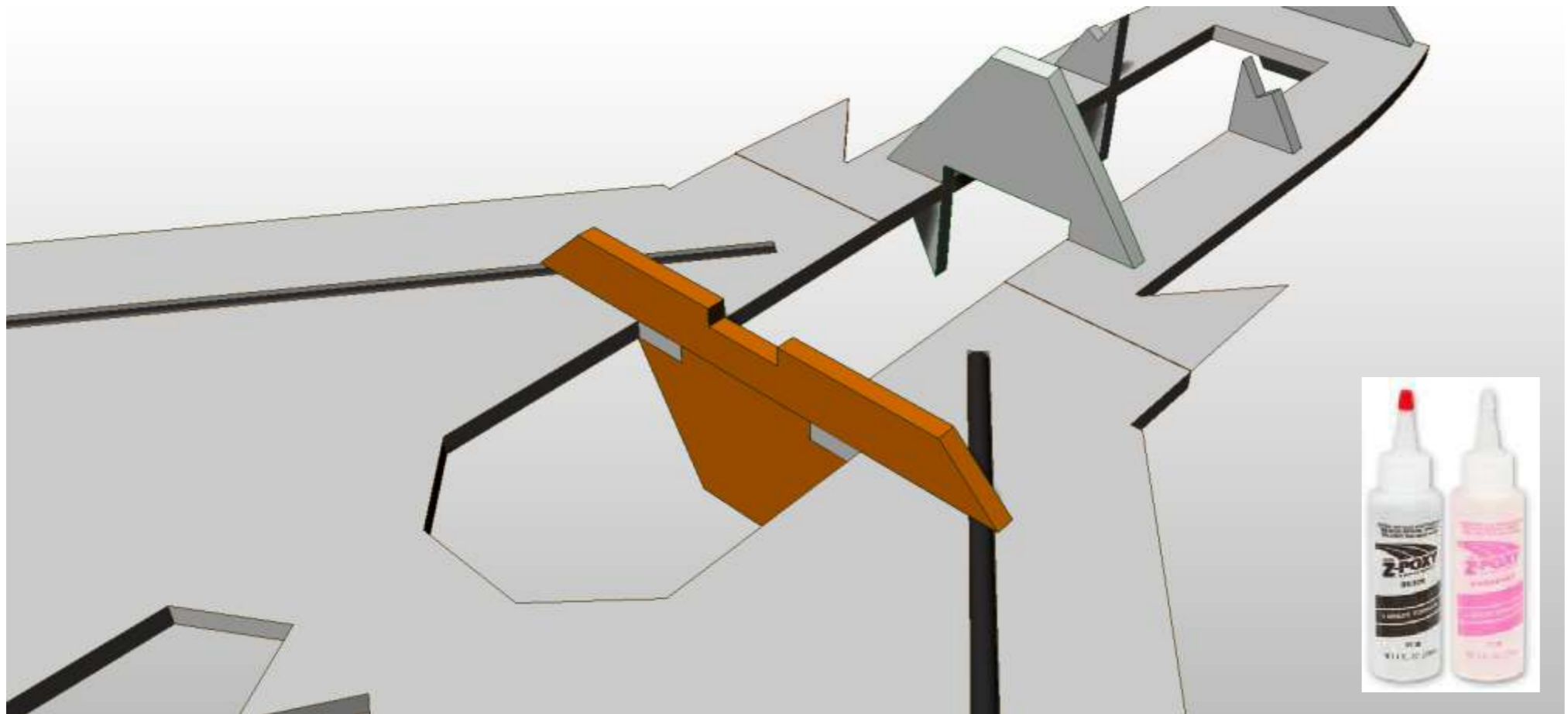

Glue the Upper corner reinforcers to the fuselage side - making sure they are 6mm back from the front of the fuselage to allow for Bulkhead 1 see in next picture.

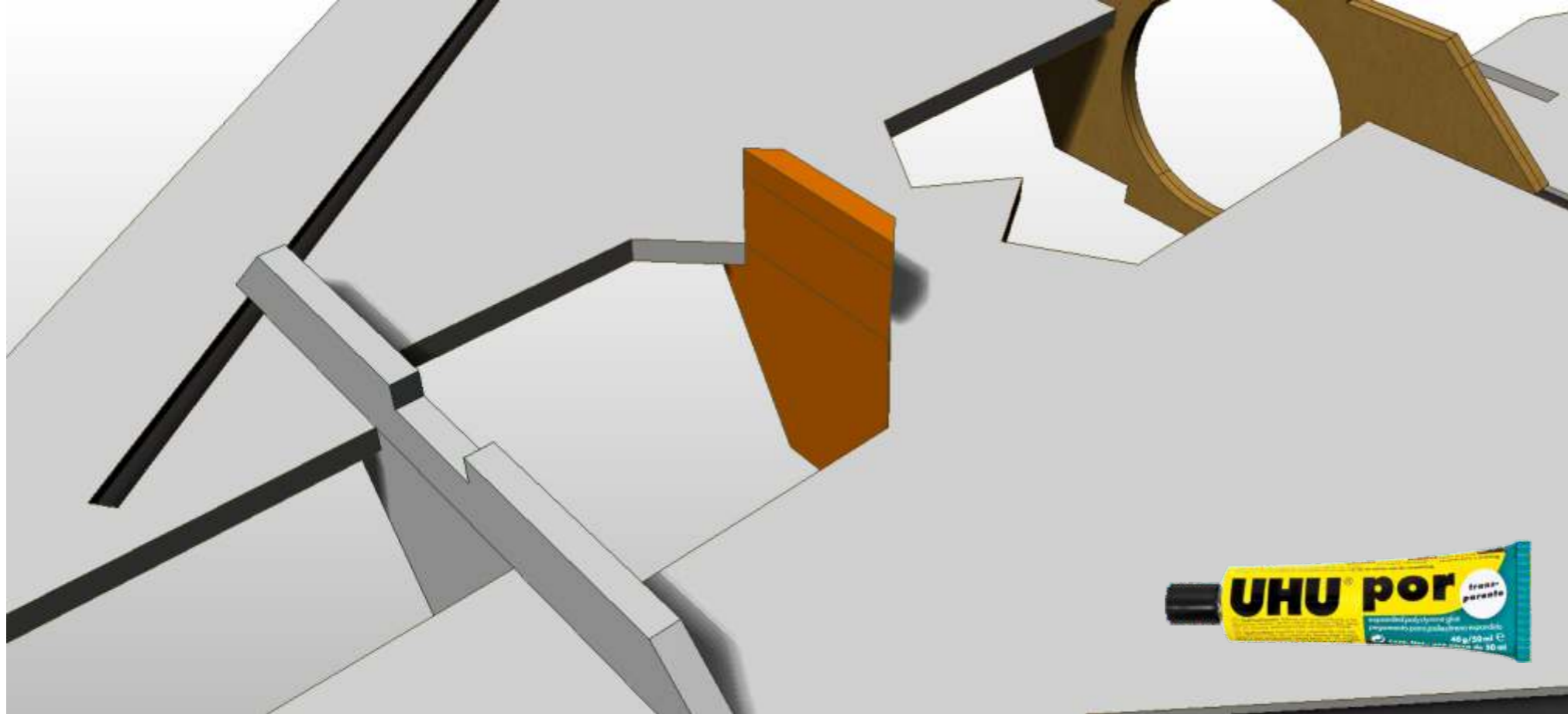

Glue fuselage 1,2 and 3 in place in the slots provided.

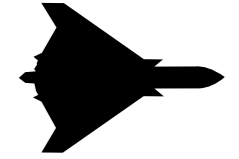



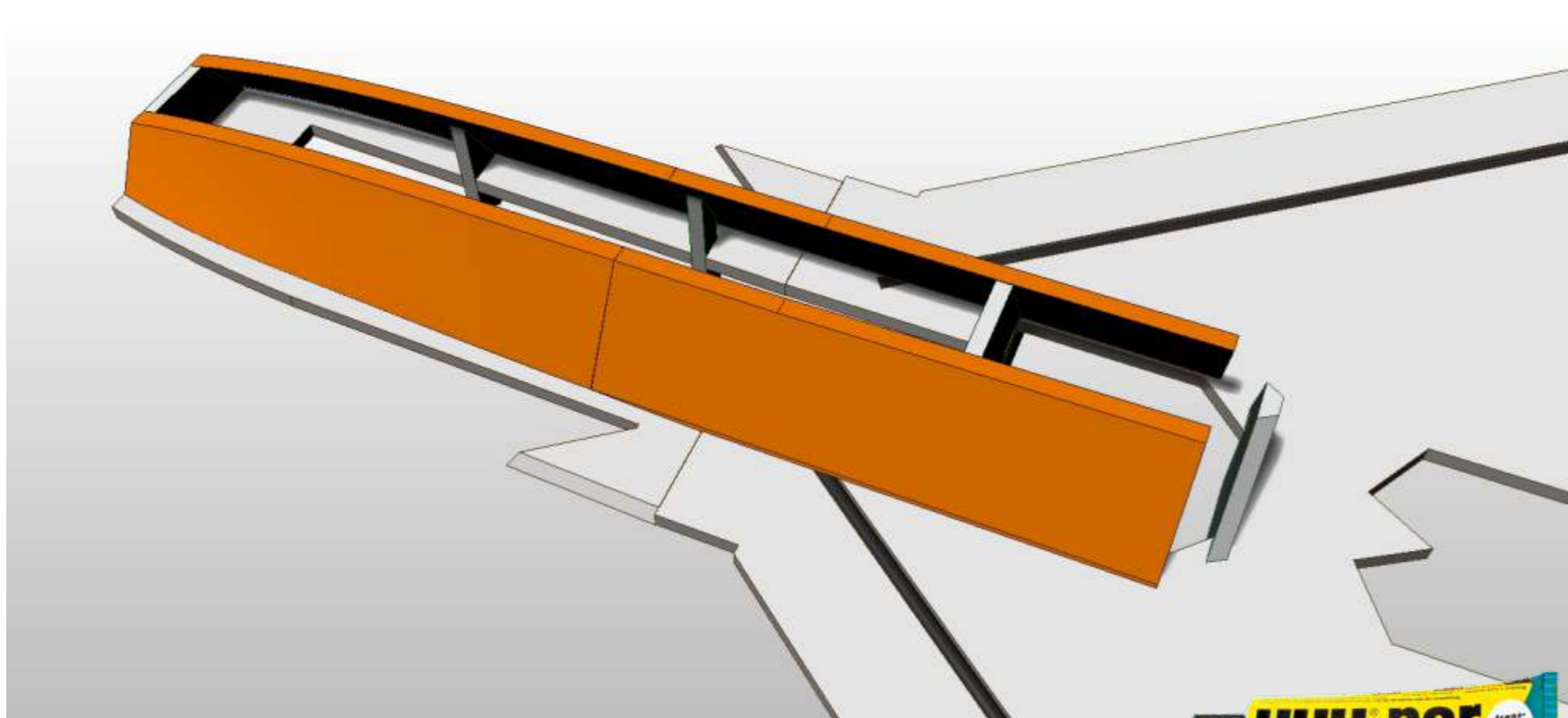

Glue the Upper corner reinforcements to the fuselage side - making sure they are 6mm back from the front of the fuselage to allow for Bulkhead 1 see in next picture.

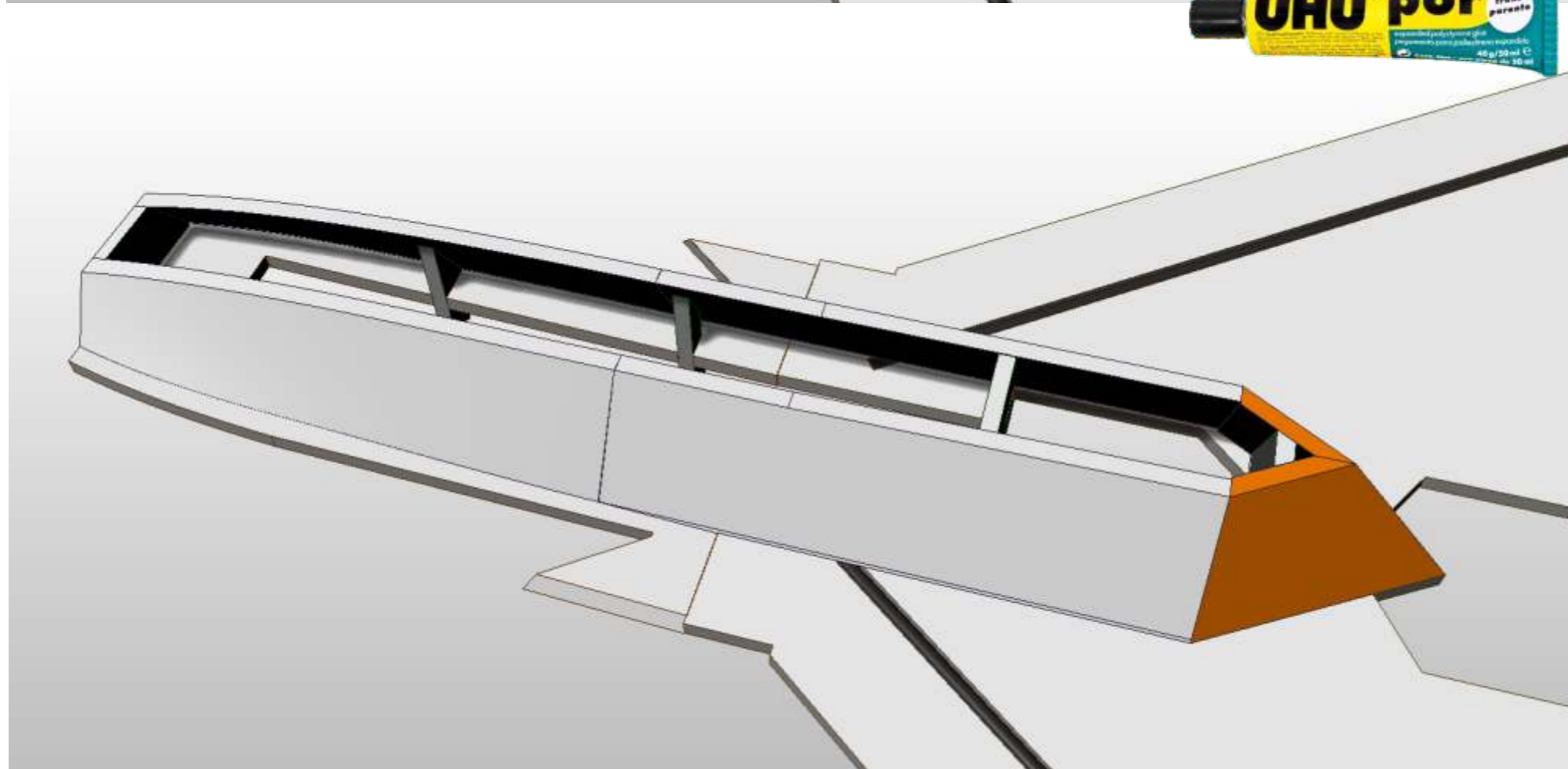

Glue fuselage 1,2 and 3 in place in the slots provided.

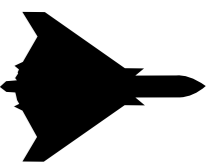

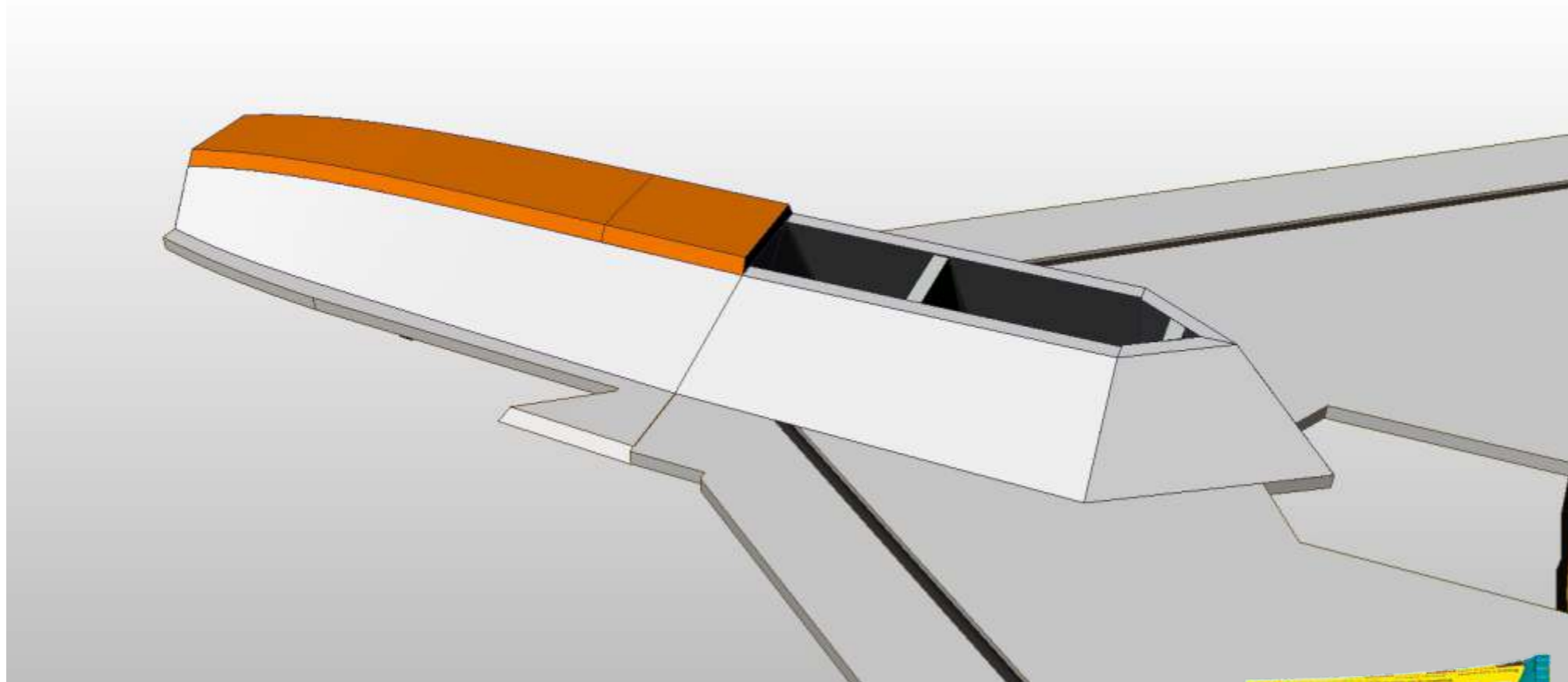

Glue the Upper corner reinforcers to the fuselage side - making sure they are 6mm back from the front of the fuselage to allow for Bulkhead 1 see in next picture.

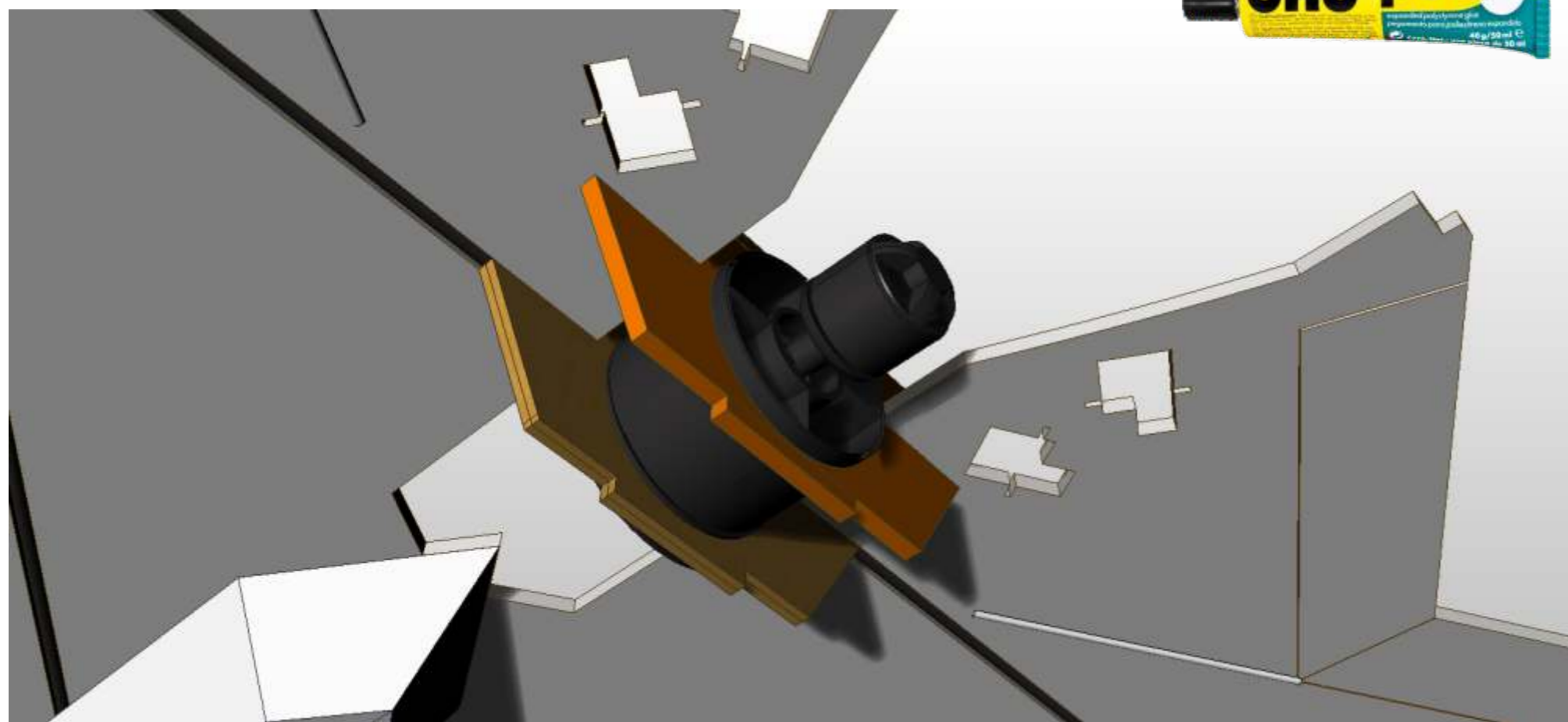

Glue fuselage 1,2 and 3 in place in the slots provided.

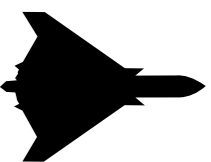

Pusher only

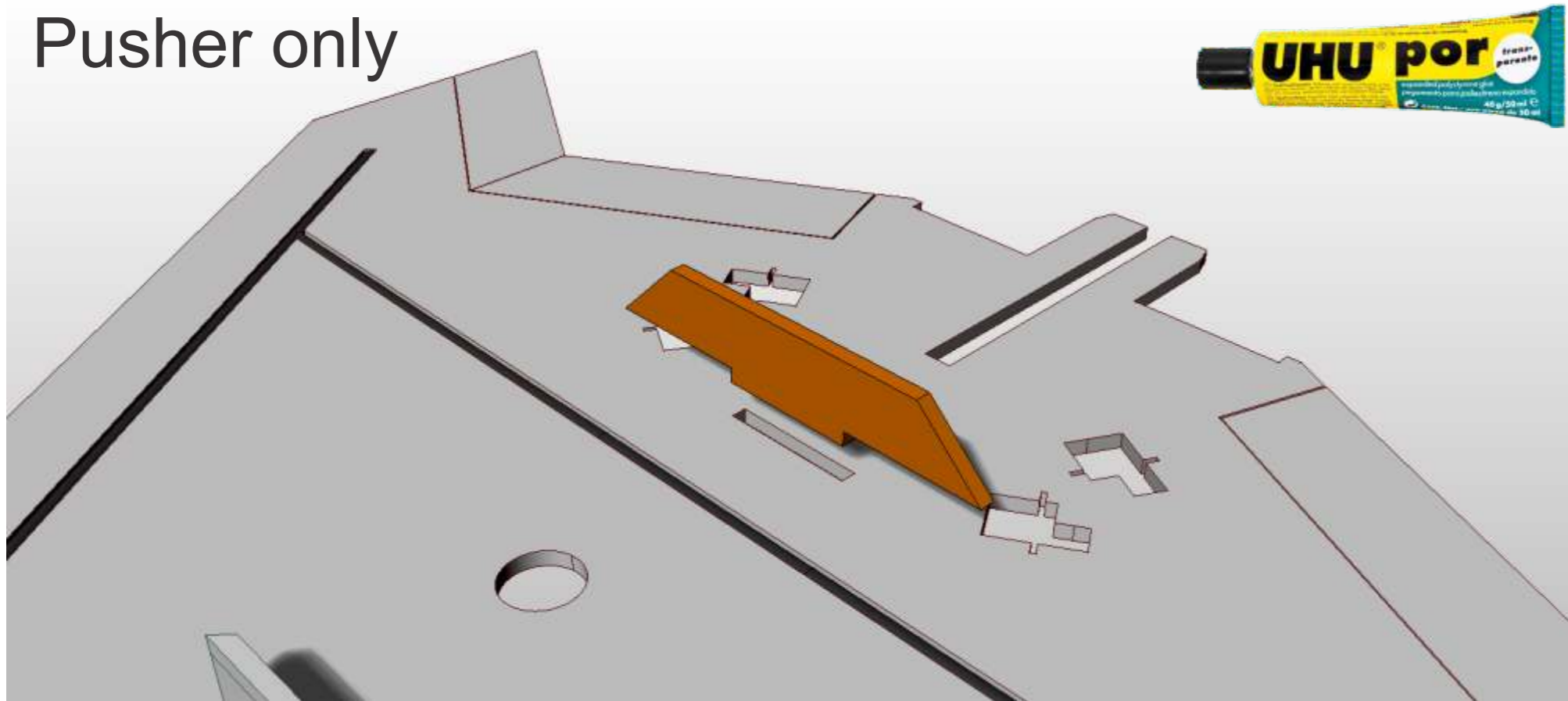

Glue the Upper corner reinforcers to the fuselage side - making sure they are 6mm back from the front of the fuselage to allow for Bulkhead 1 see in next picture.

Pusher only

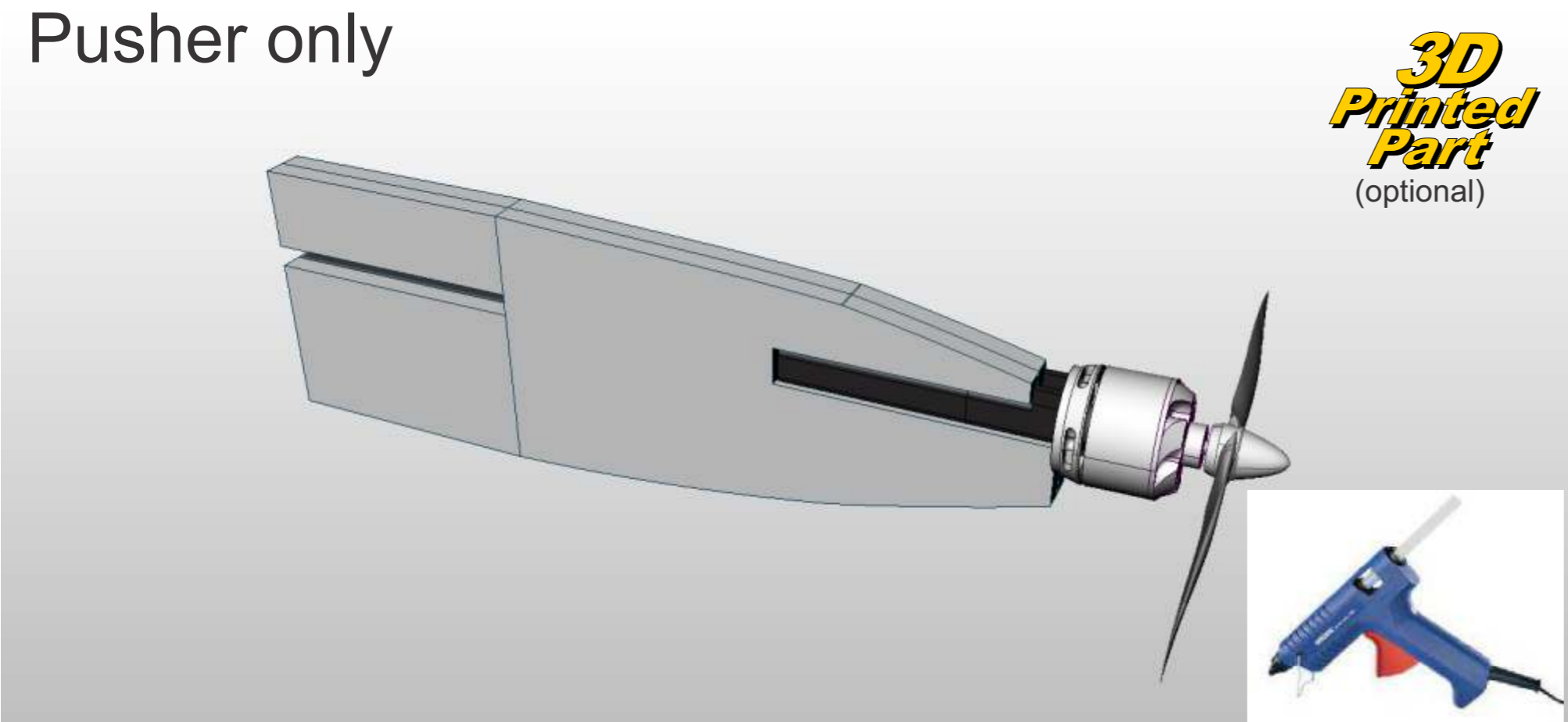

Glue fuselage 1,2 and 3 in place in the slots provided.

Glue the motor stick mount into the motor mount using hot melt glue.

Hobbyking - SKU:OR004-00602

Alternatively there is a 3d print version available.

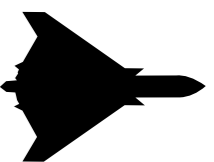

# Pusher only

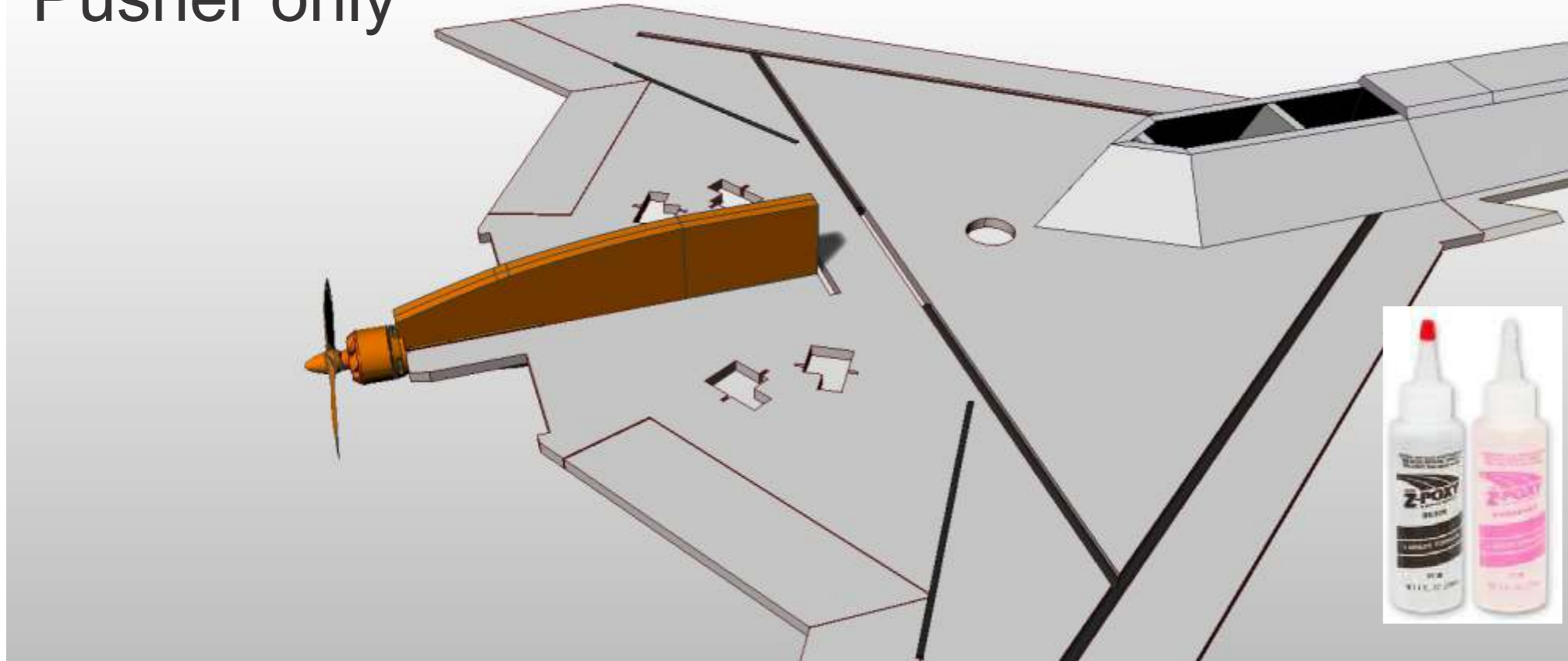

Glue the Upper corner reinforcers to the fuselage side - making sure they are 6mm back from the front of the fuselage to allow for Bulkhead 1 see in next picture.

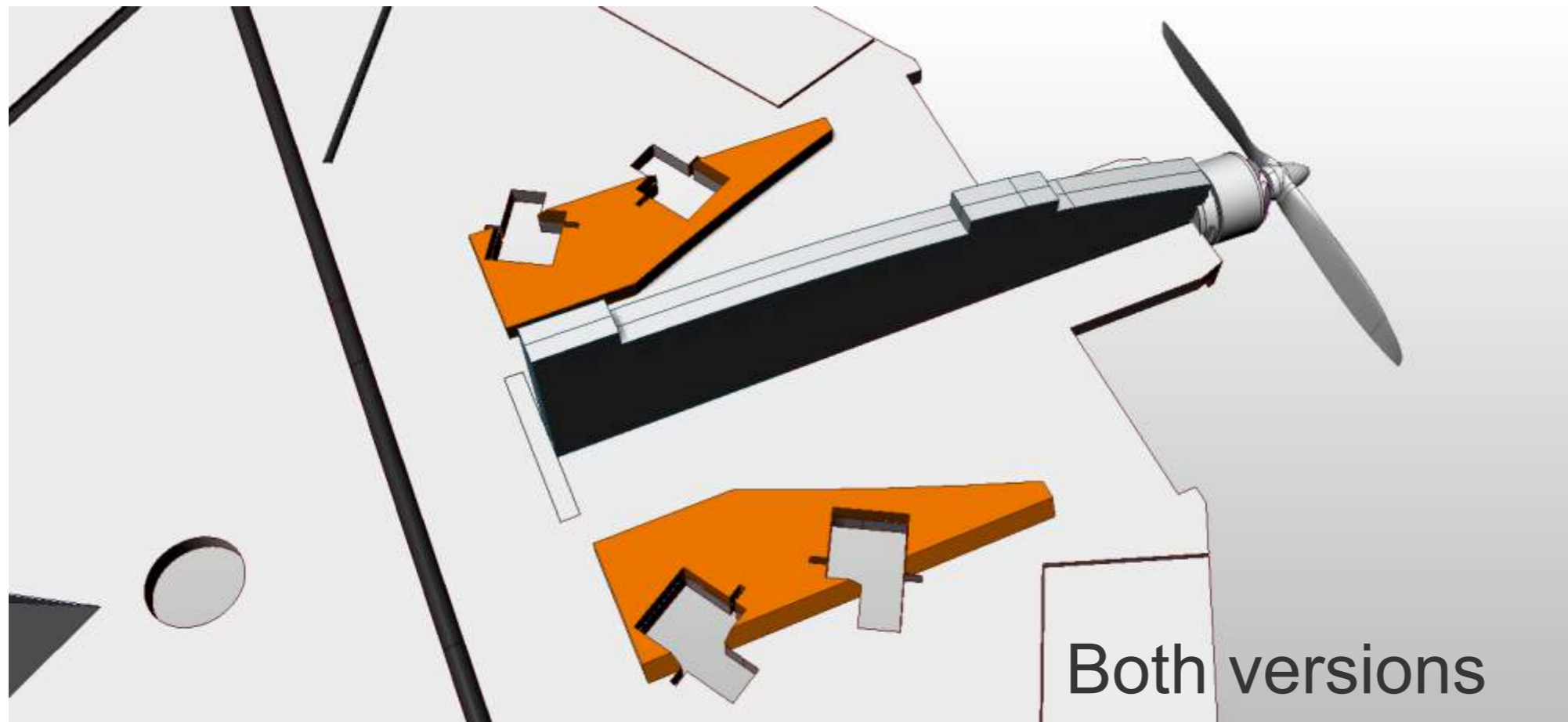

Glue fuselage 1,2 and 3 in place in the slots provided.

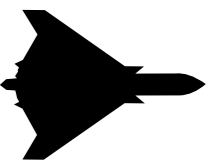

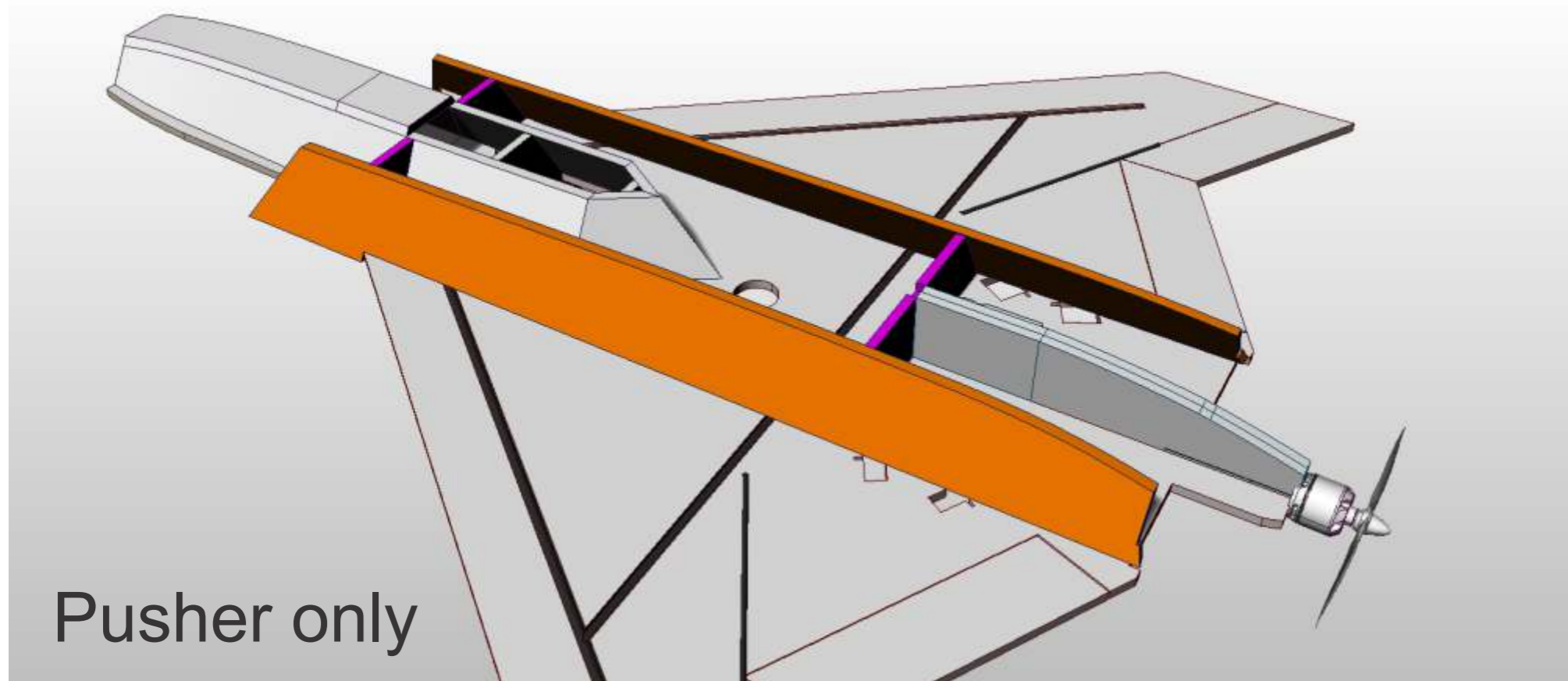

Glue the Upper corner reinforcements to the fuselage side - making sure they are 6mm back from the front of the fuselage to allow for Bulkhead 1 see in next picture.

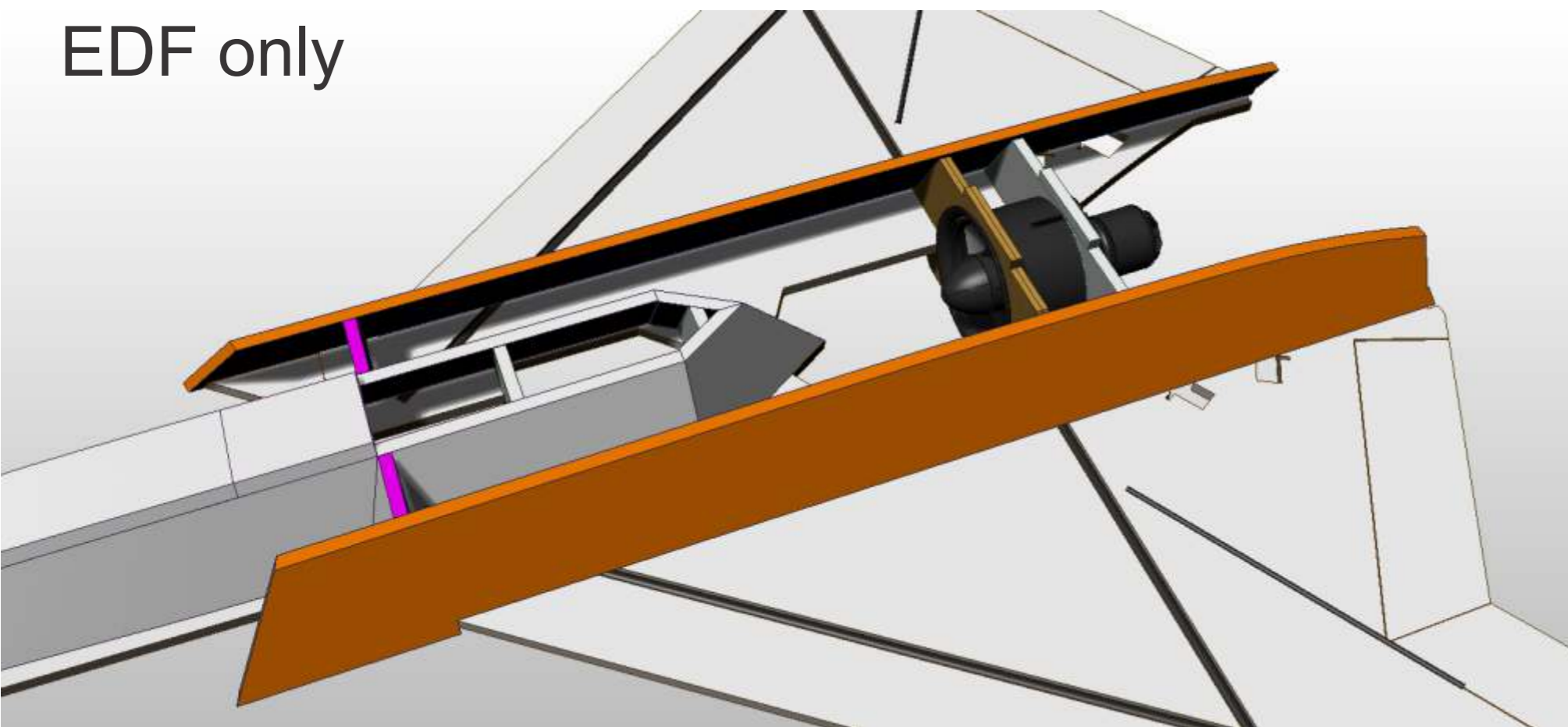

Glue fuselage 1,2 and 3 in place in the slots provided.

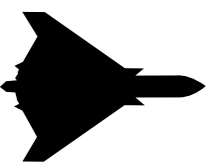

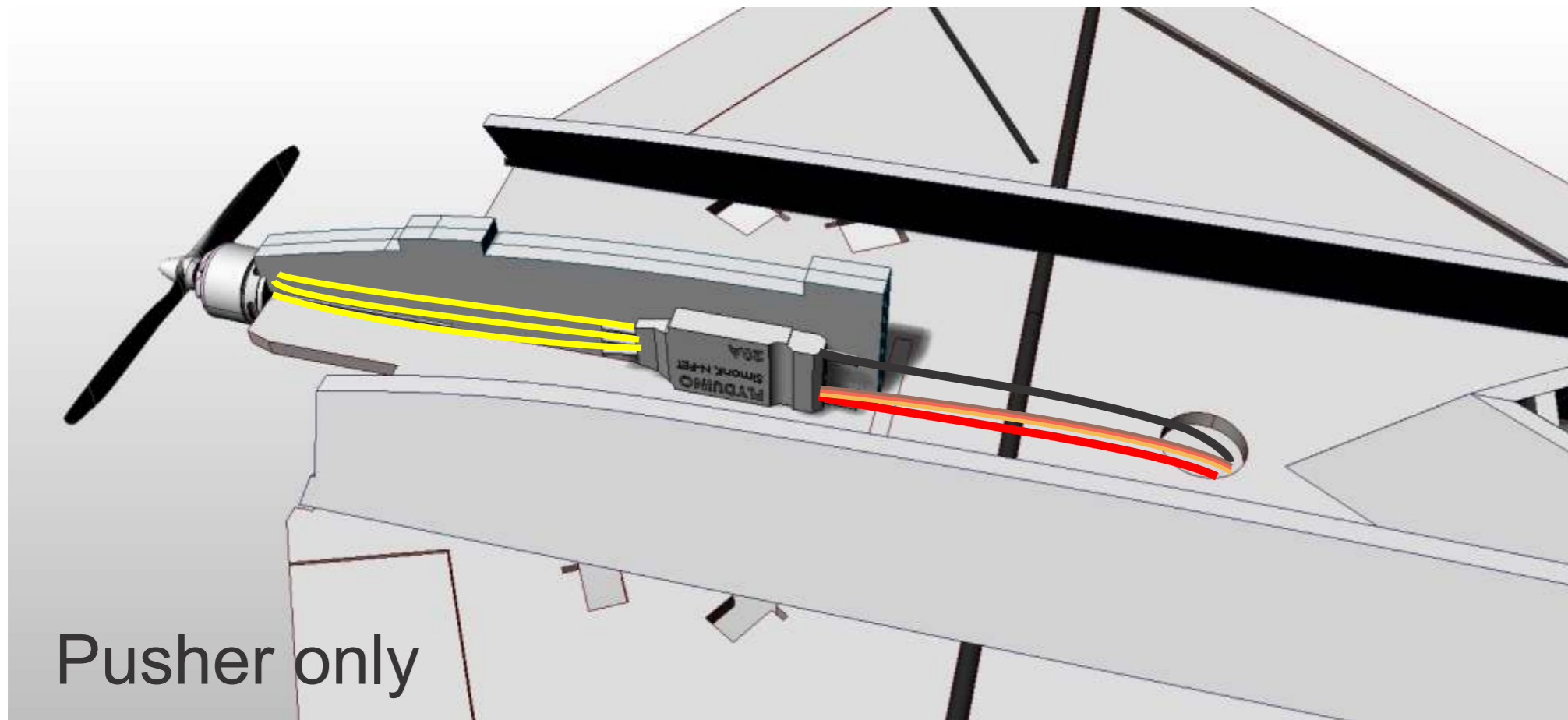

Glue the Upper corner reinforcers to the fuselage side - making sure they are 6mm back from the front of the fuselage to allow for Bulkhead 1 see in next picture.

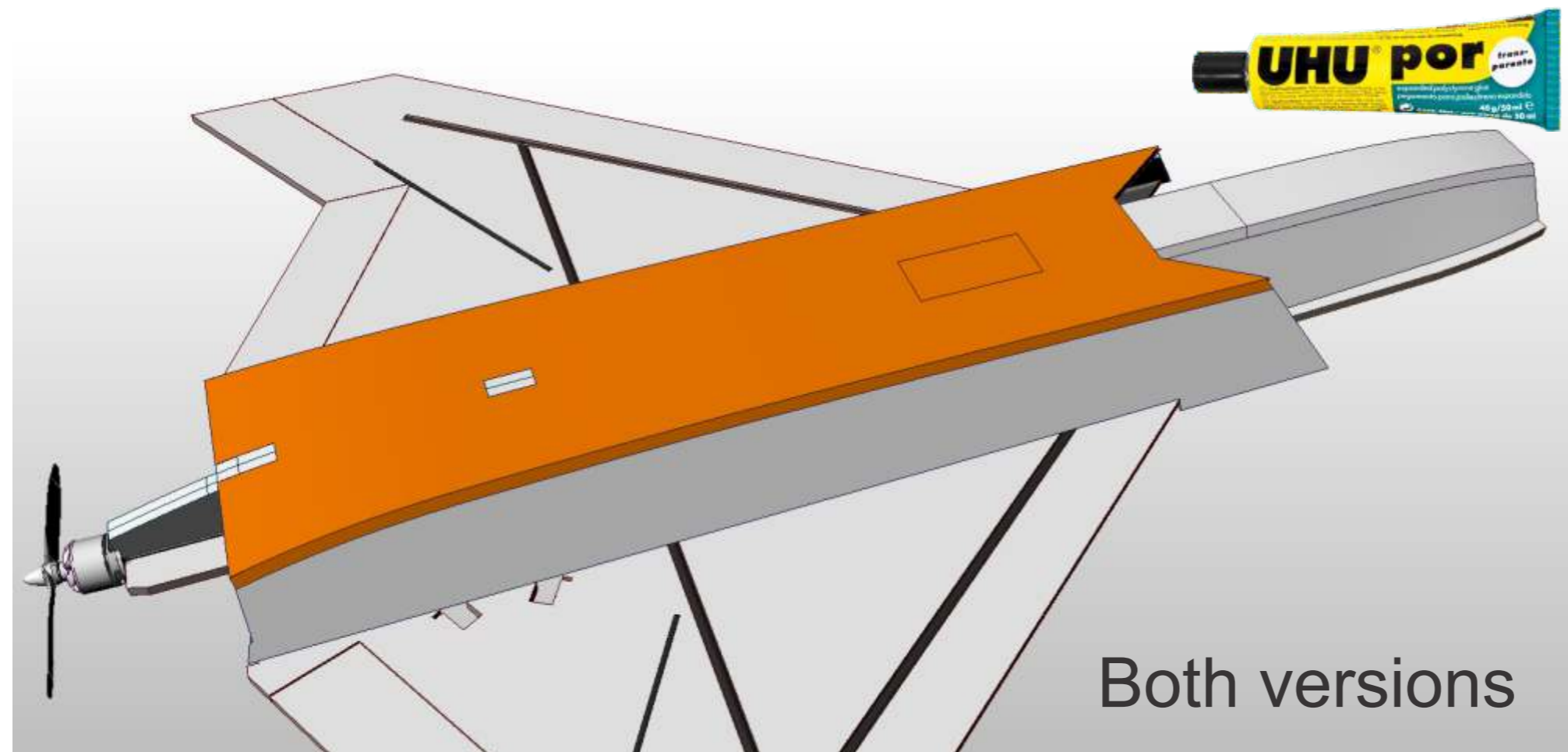

Glue fuselage 1,2 and 3 in place in the slots provided.

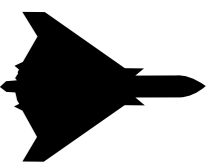

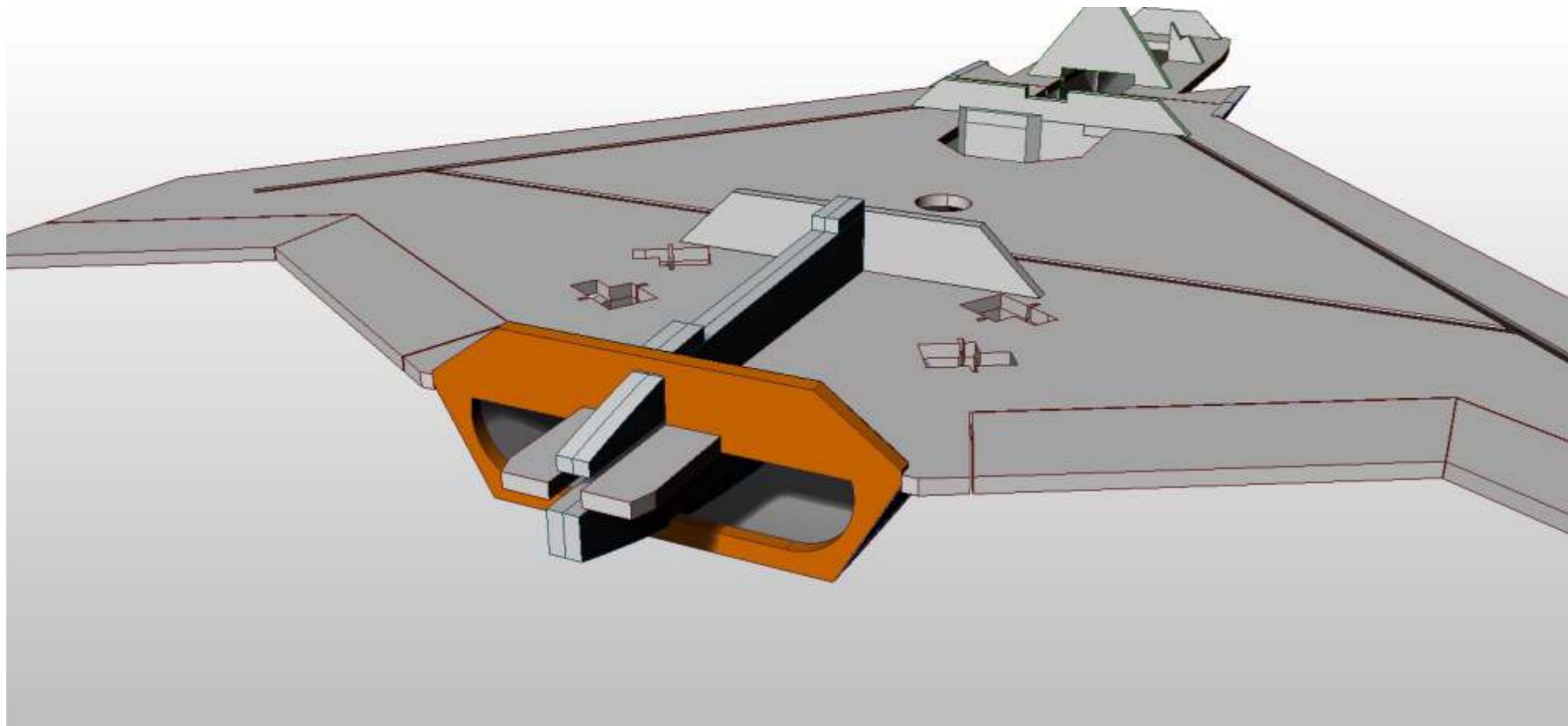

Glue the Upper corner reinforcements to the fuselage side - making sure they are 6mm back from the front of the fuselage to allow for Bulkhead 1 see in next picture.

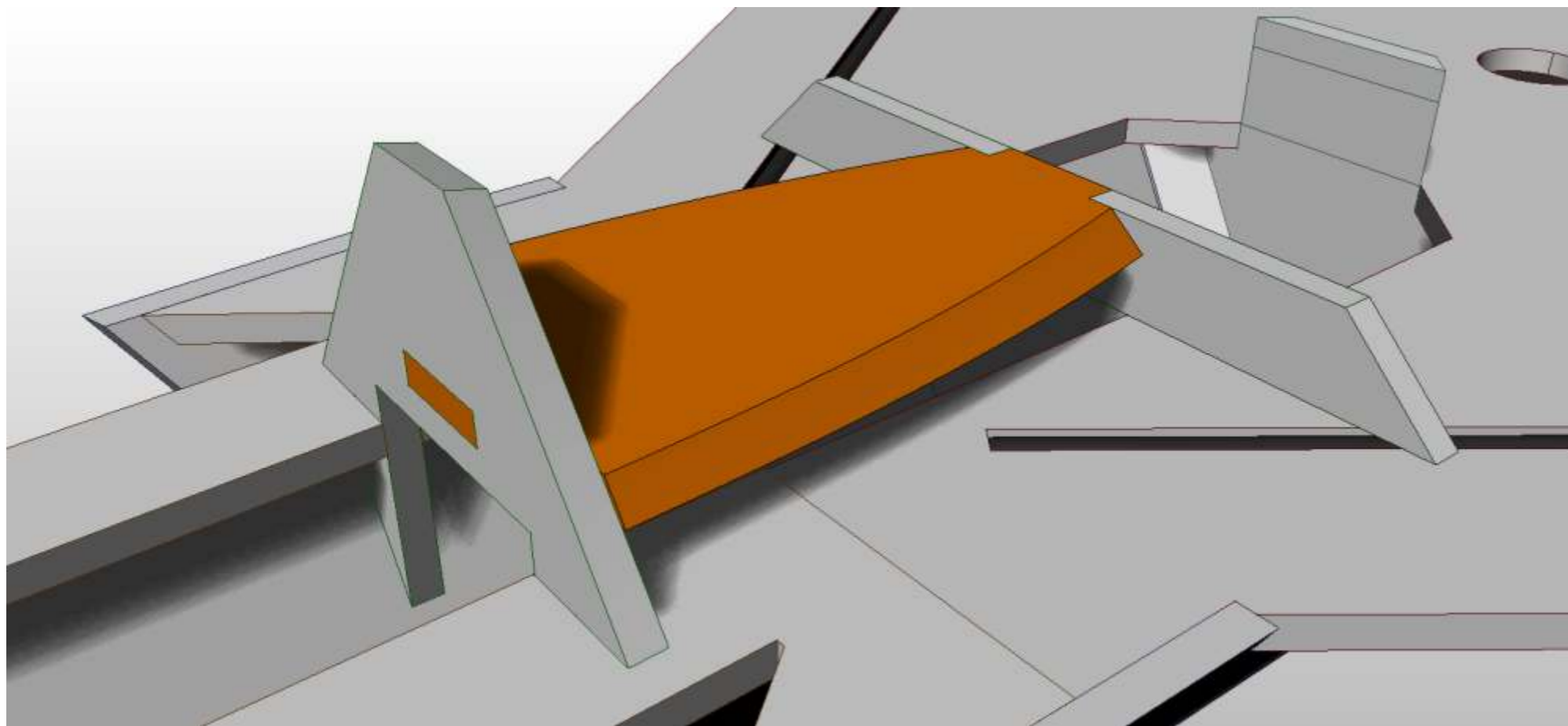

Glue fuselage 1,2 and 3 in place in the slots provided.

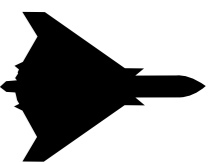

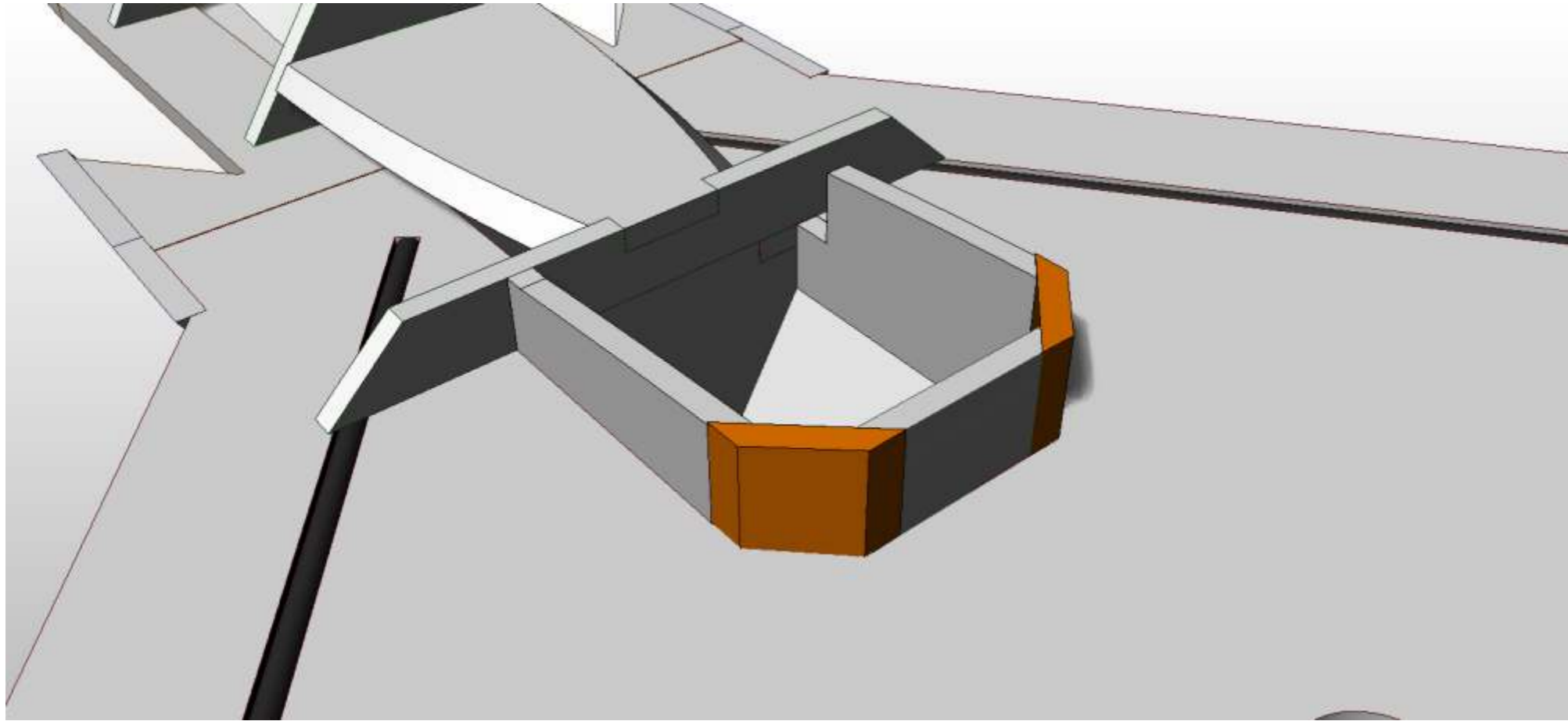

Glue the Upper corner reinforcers to the fuselage side - making sure they are 6mm back from the front of the fuselage to allow for Bulkhead 1 see in next picture.

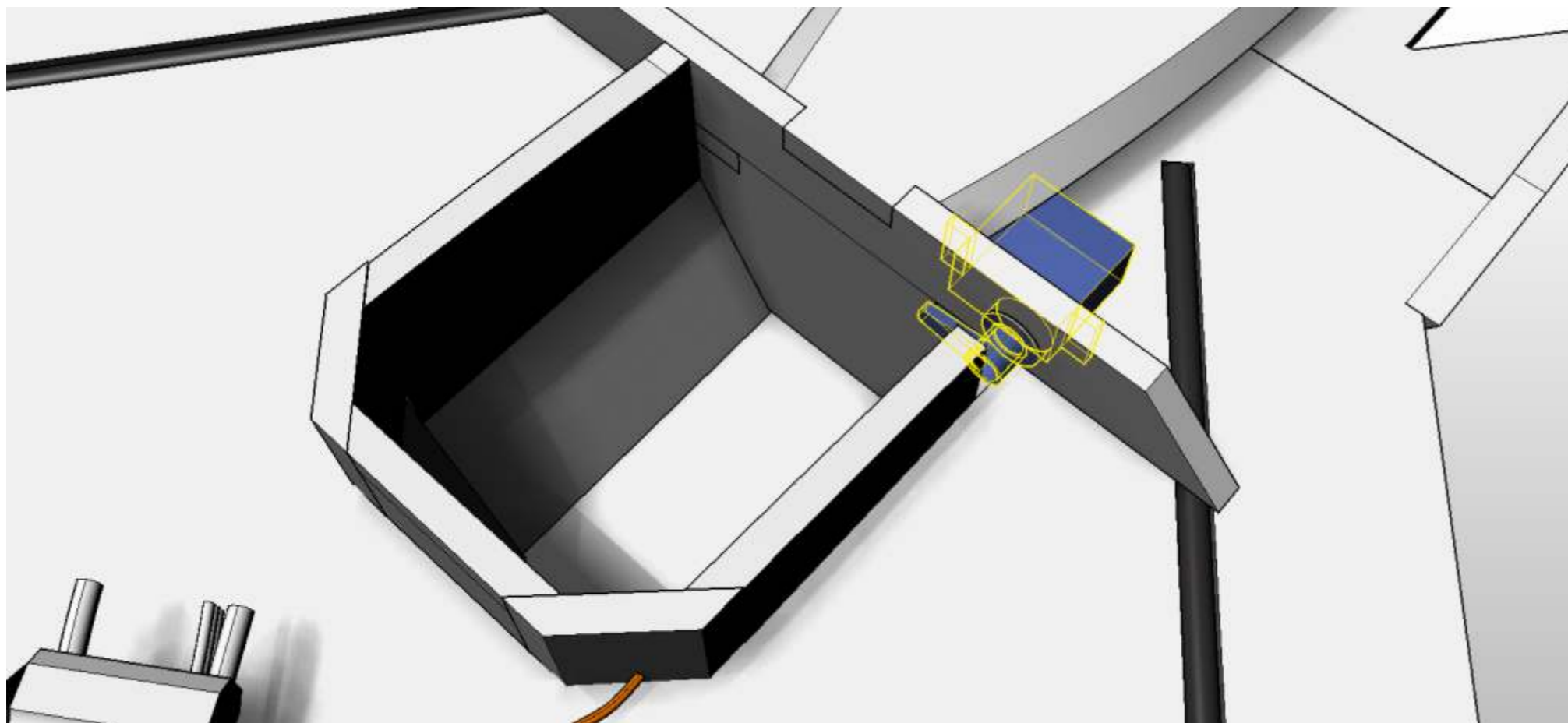

Glue fuselage 1,2 and 3 in place in the slots provided.

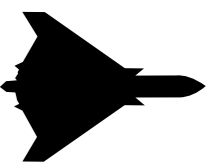



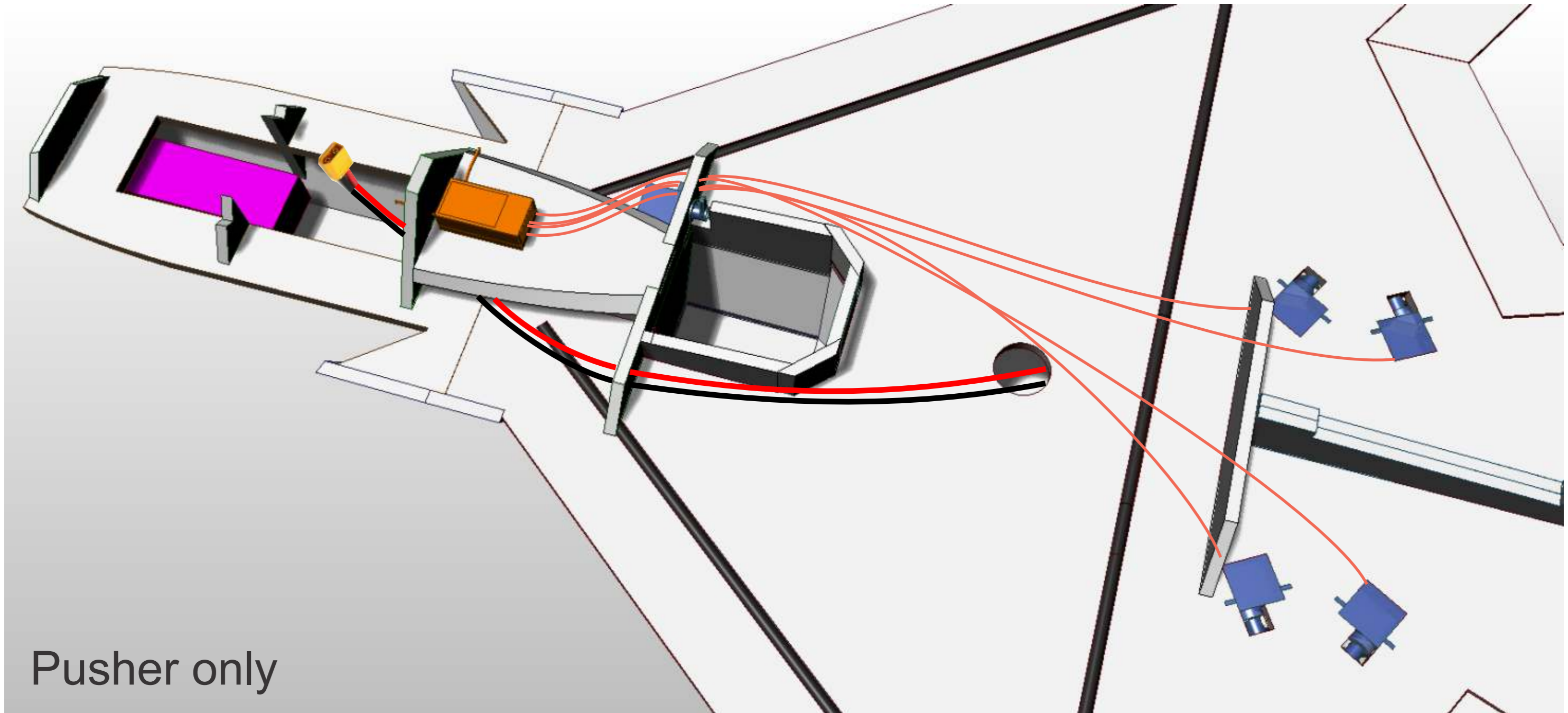

Pusher only

Connect the ESC to the EDF motor running under the 'bridge' above the EDF casing.

Run the battery & Servo cable from the ESC, back under the 'bridge' and then through the wing tunnel into the fuselage.

Once wired up, thoroughly test all electronics to ensure they function correctly, making sure there are no loose connections anywhere or dry

Do the same on the other wing.

Solder the red power cables together along with a third red cable running to the

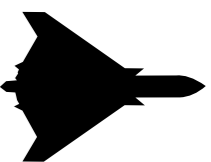

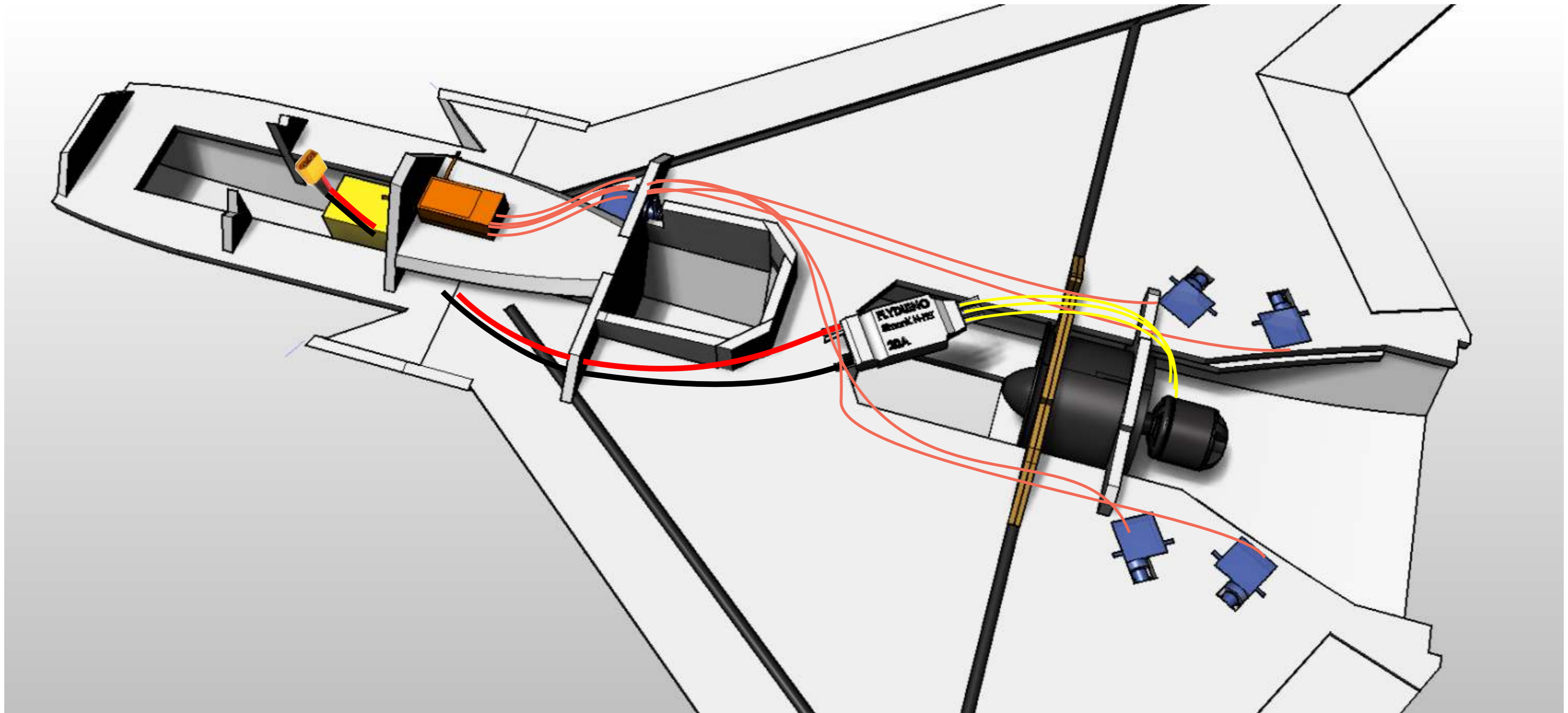

Connect the ESC to the EDF motor running under the 'bridge' above the EDF casing.

Run the battery & Servo cable from the ESC, back under the 'bridge' and then through the wing tunnel into the fuselage.

Once wired up, thoroughly test all electronics to ensure they function correctly, making sure there are no loose connections anywhere or dry

Do the same on the other wing.

Solder the red power cables together along with a third red cable running to the

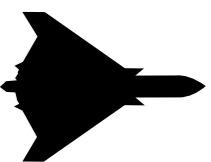

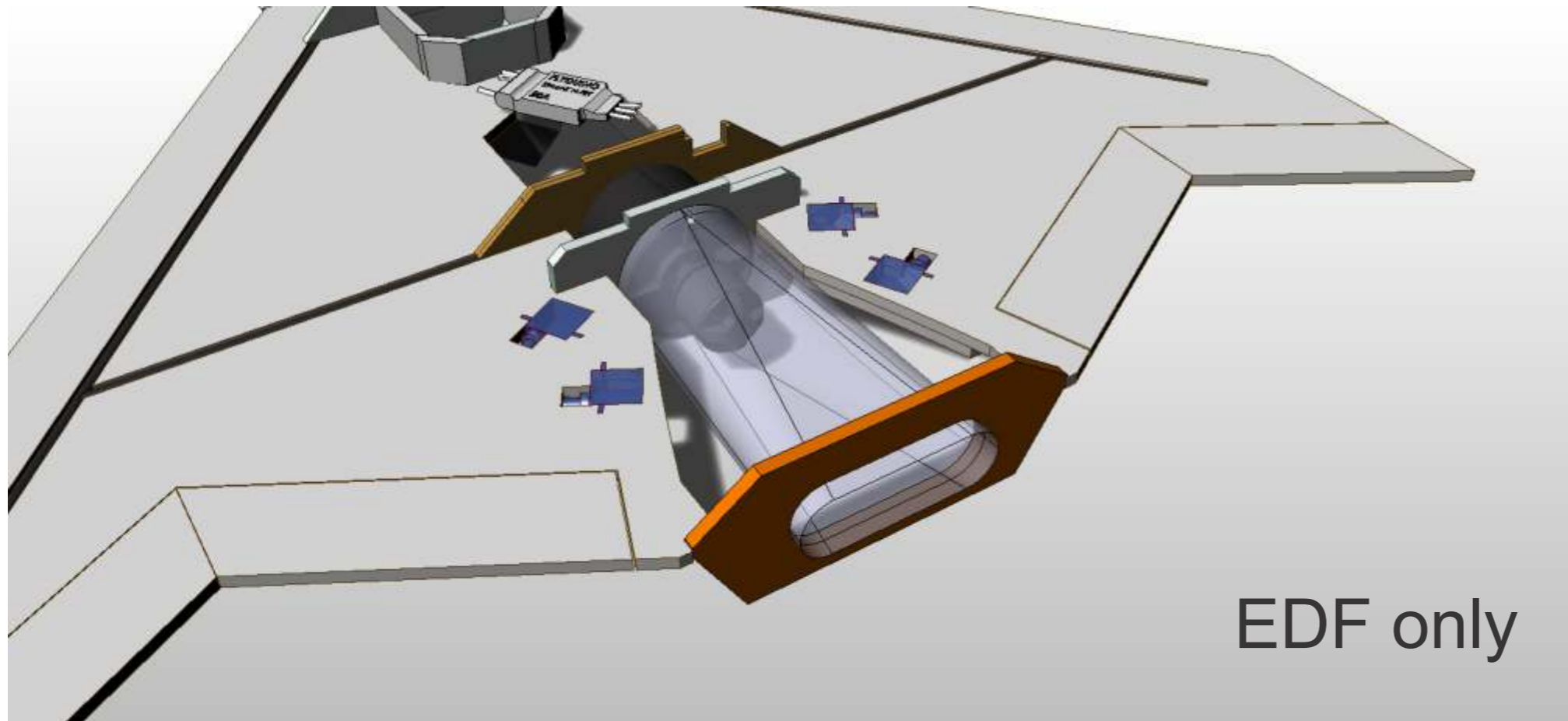

Glue the Upper corner reinforcements to the fuselage side - making sure they are 6mm back from the front of the fuselage to allow for Bulkhead 1 see in next picture.

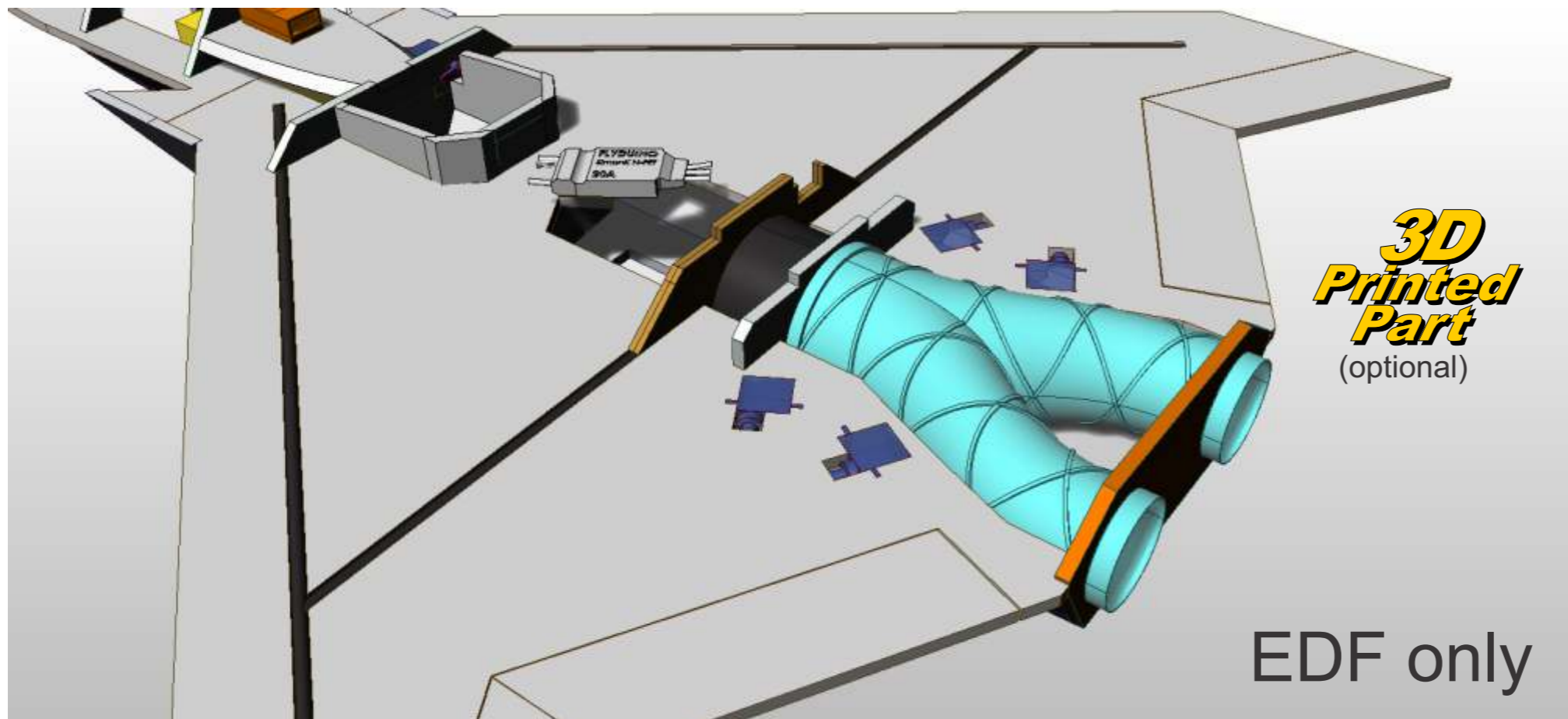

Glue fuselage 1,2 and 3 in place in the slots provided.

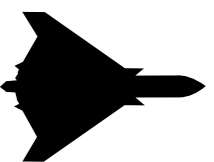

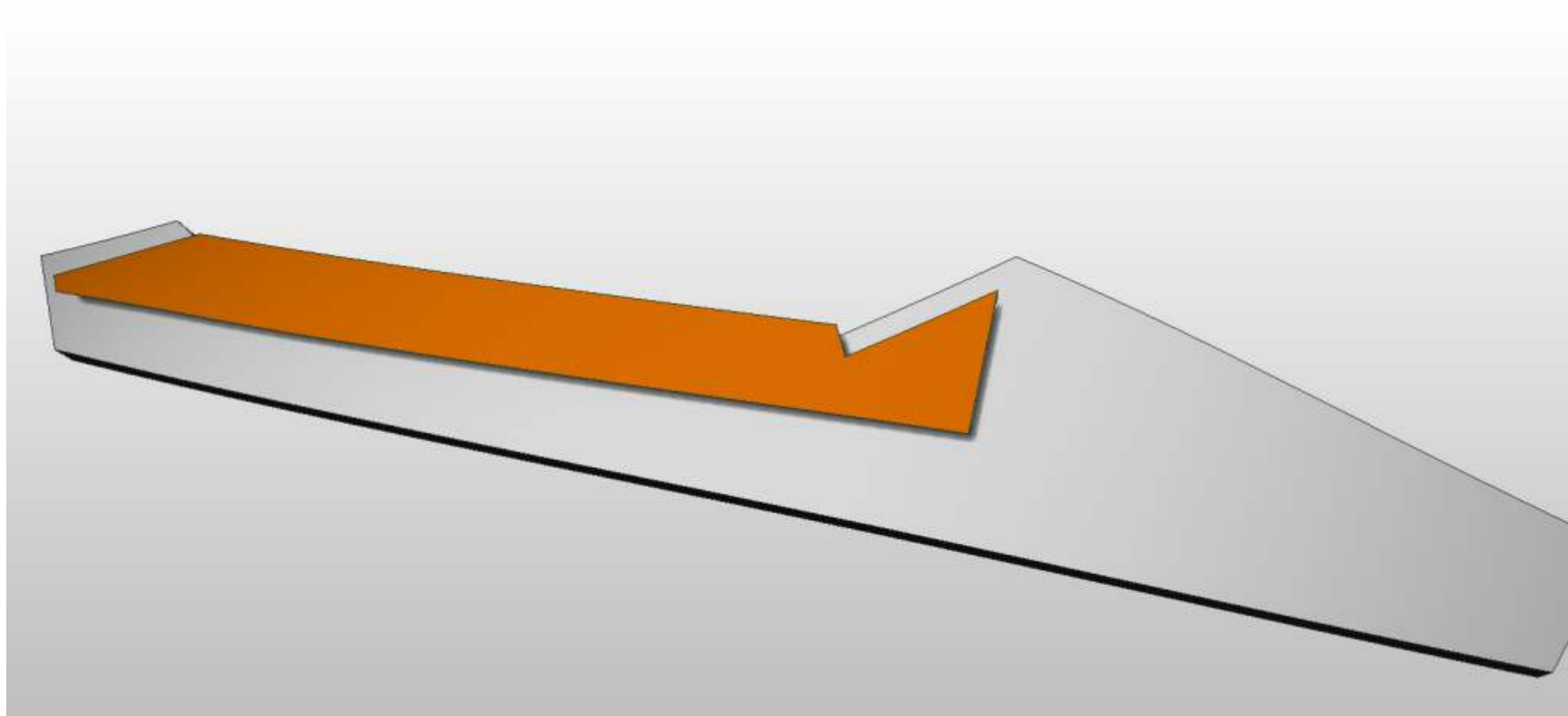

Glue the Upper corner reinforcers to the fuselage side - making sure they are 6mm back from the front of the fuselage to allow for Bulkhead 1 see in next picture.

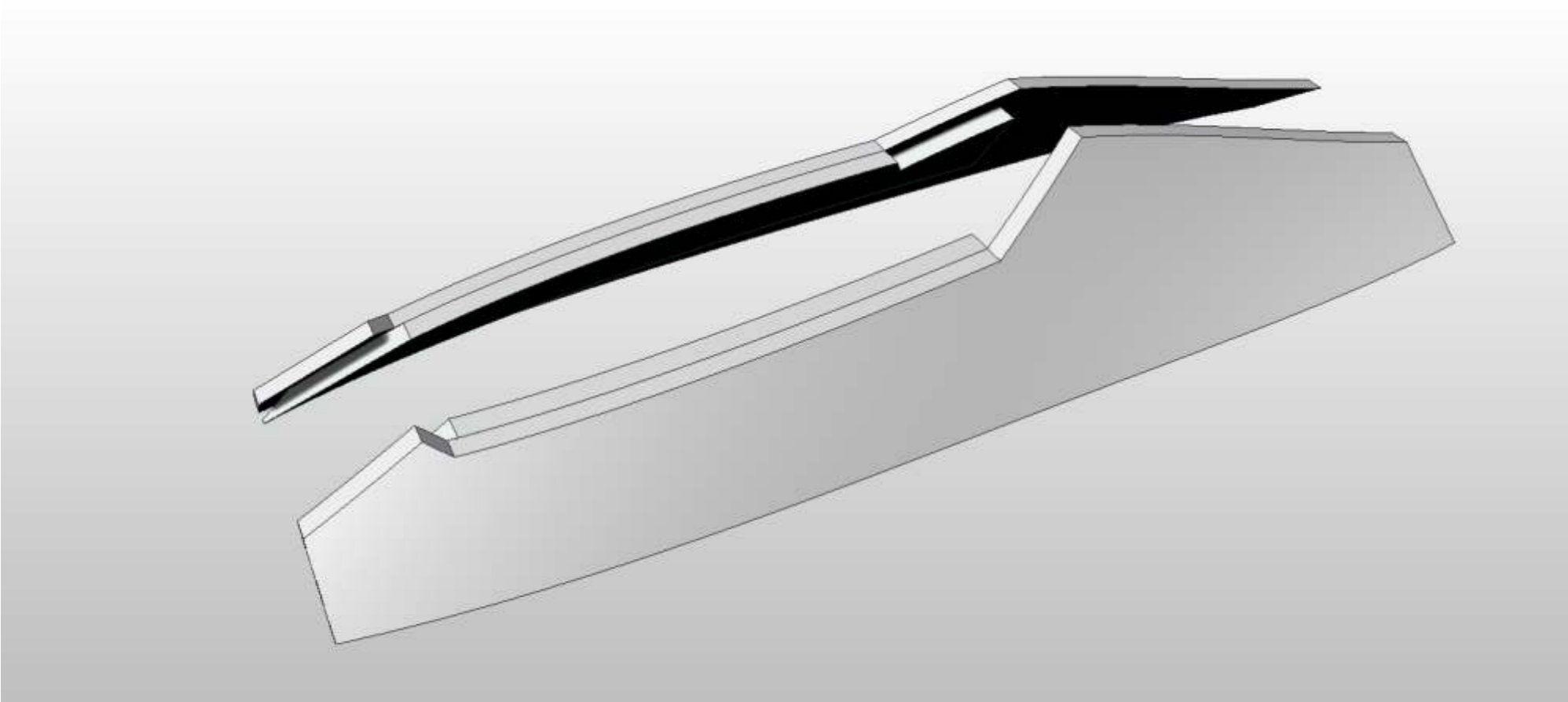

Glue fuselage 1,2 and 3 in place in the slots provided.

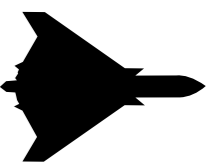

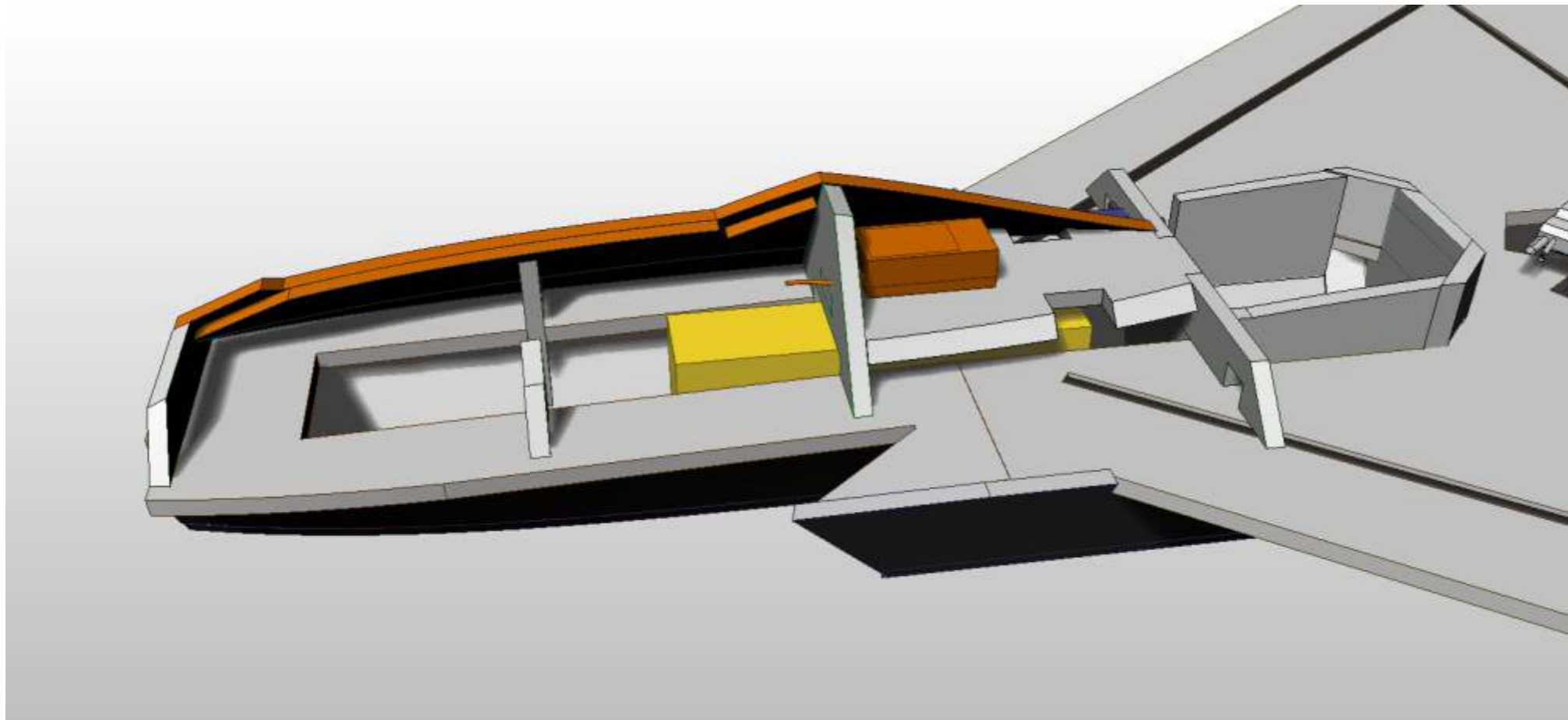

Glue the Upper corner reinforcements to the fuselage side - making sure they are 6mm back from the front of the fuselage to allow for Bulkhead 1 see in next picture.

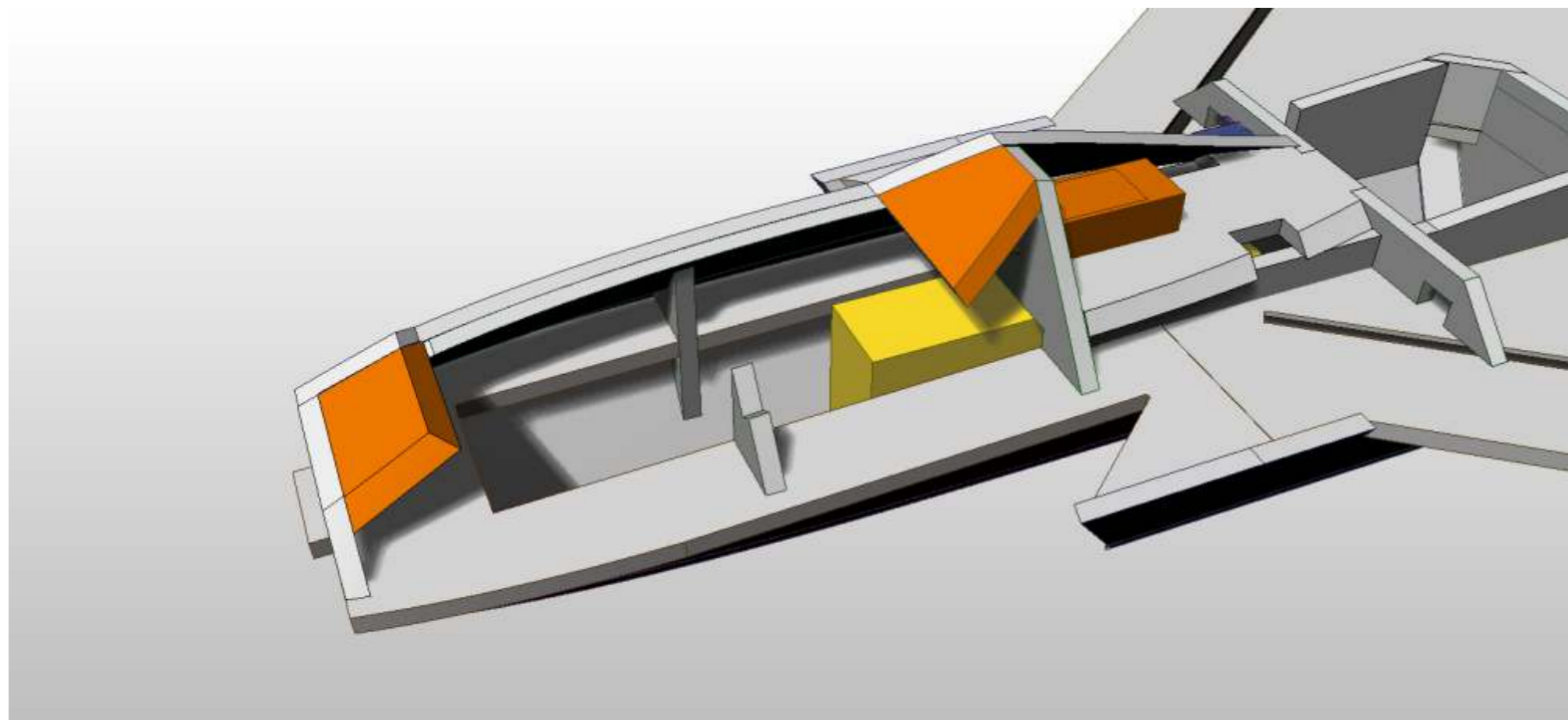

Glue fuselage 1,2 and 3 in place in the slots provided.

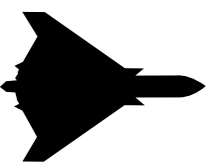

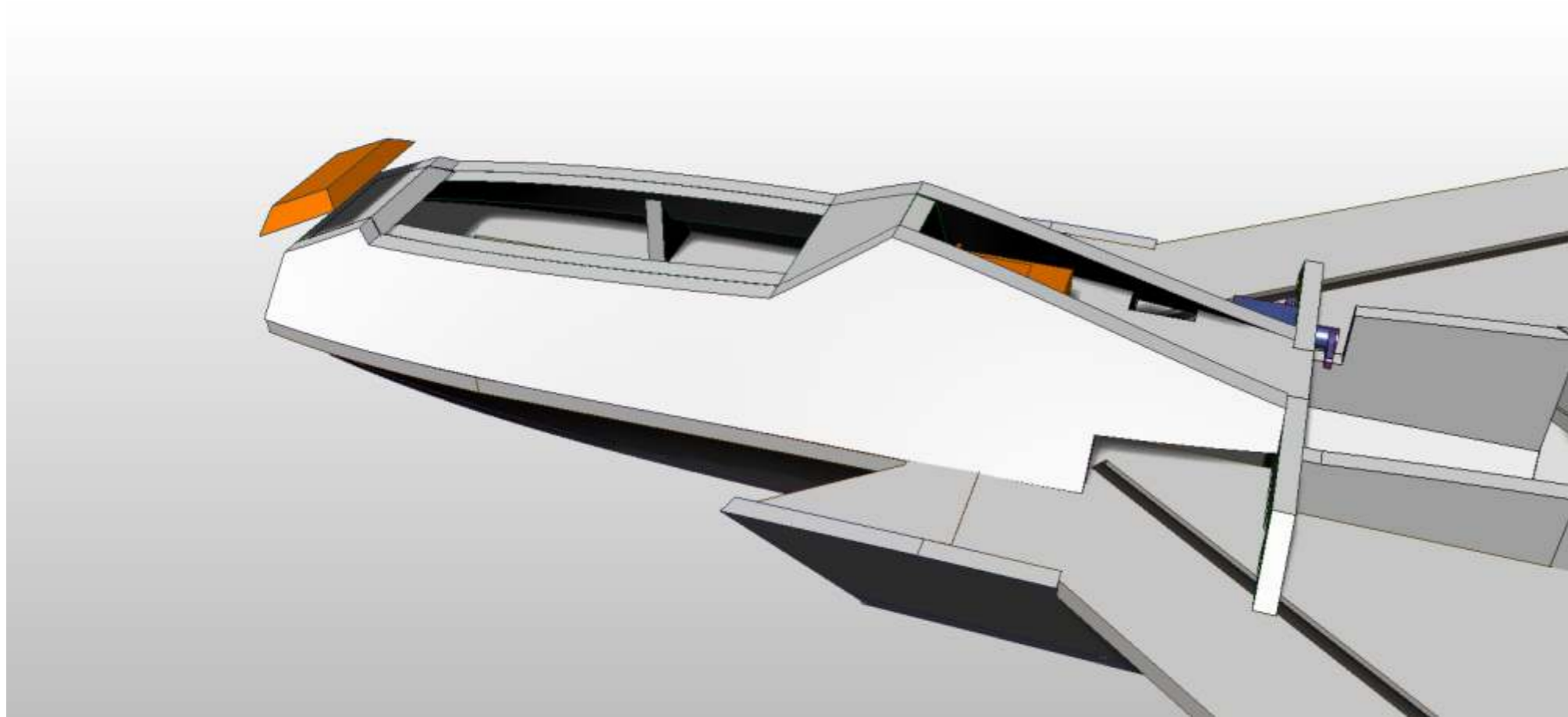

Glue the Upper corner reinforcements to the fuselage side - making sure they are 6mm back from the front of the fuselage to allow for Bulkhead 1 see in next picture.

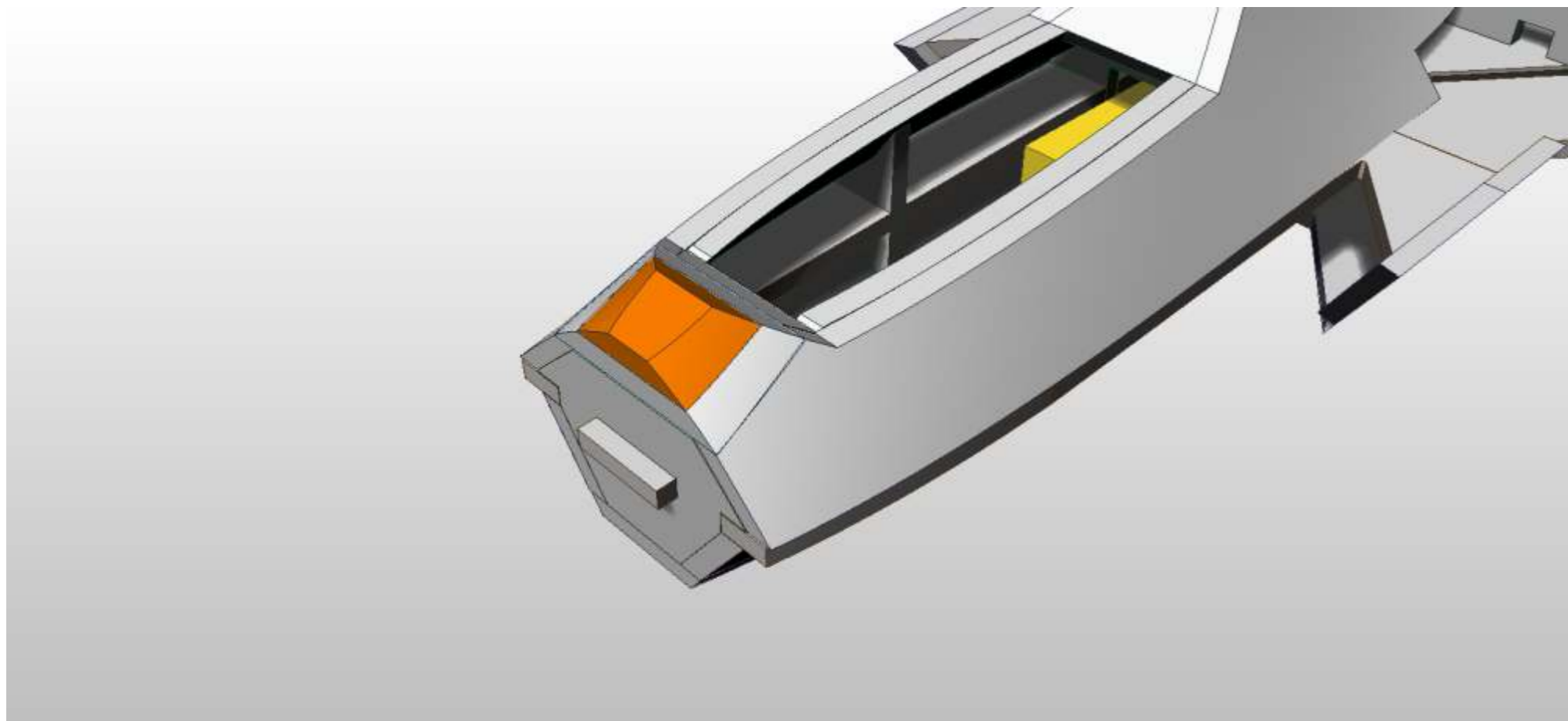

Glue fuselage 1,2 and 3 in place in the slots provided.

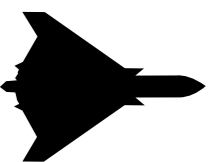

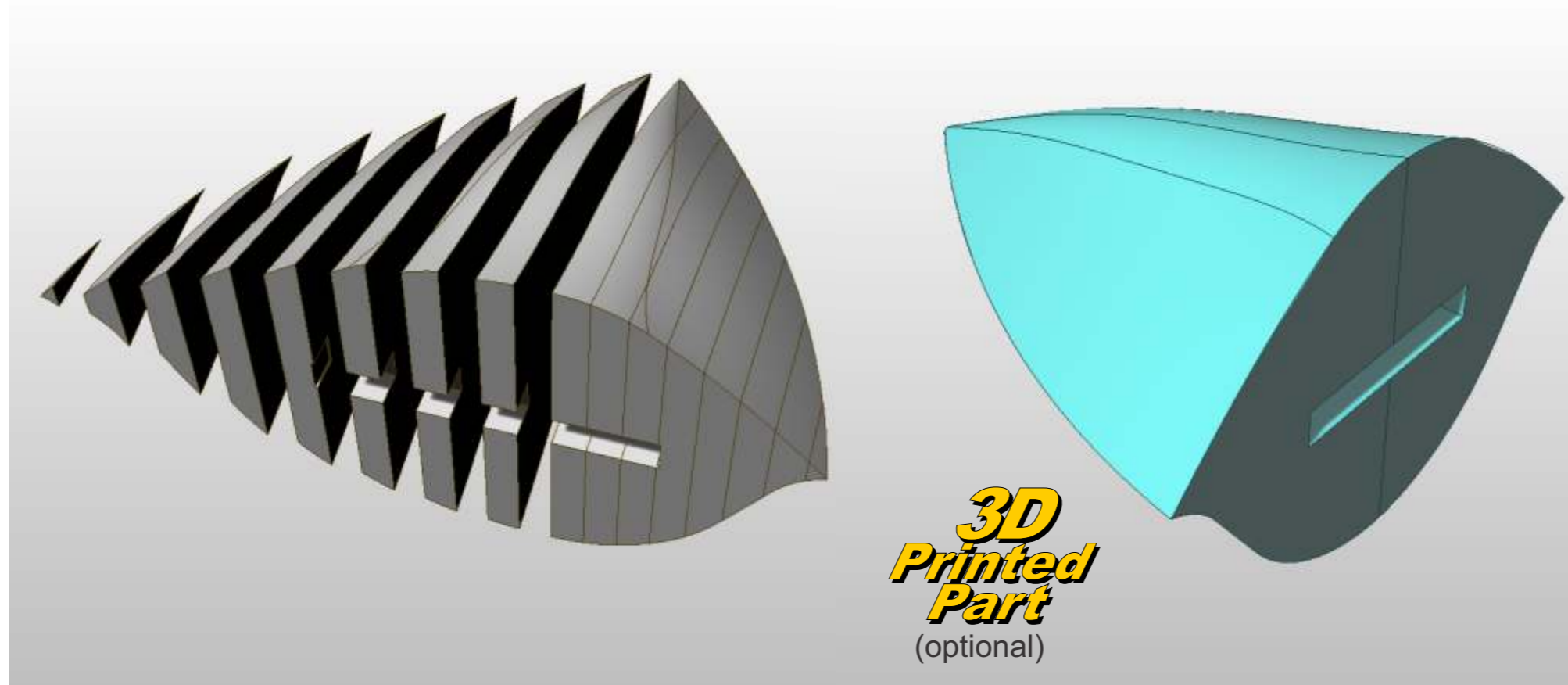

Glue the Upper corner reinforcers to the fuselage side - making sure they are 6mm back from the front of the fuselage to allow for Bulkhead 1 see in next picture.

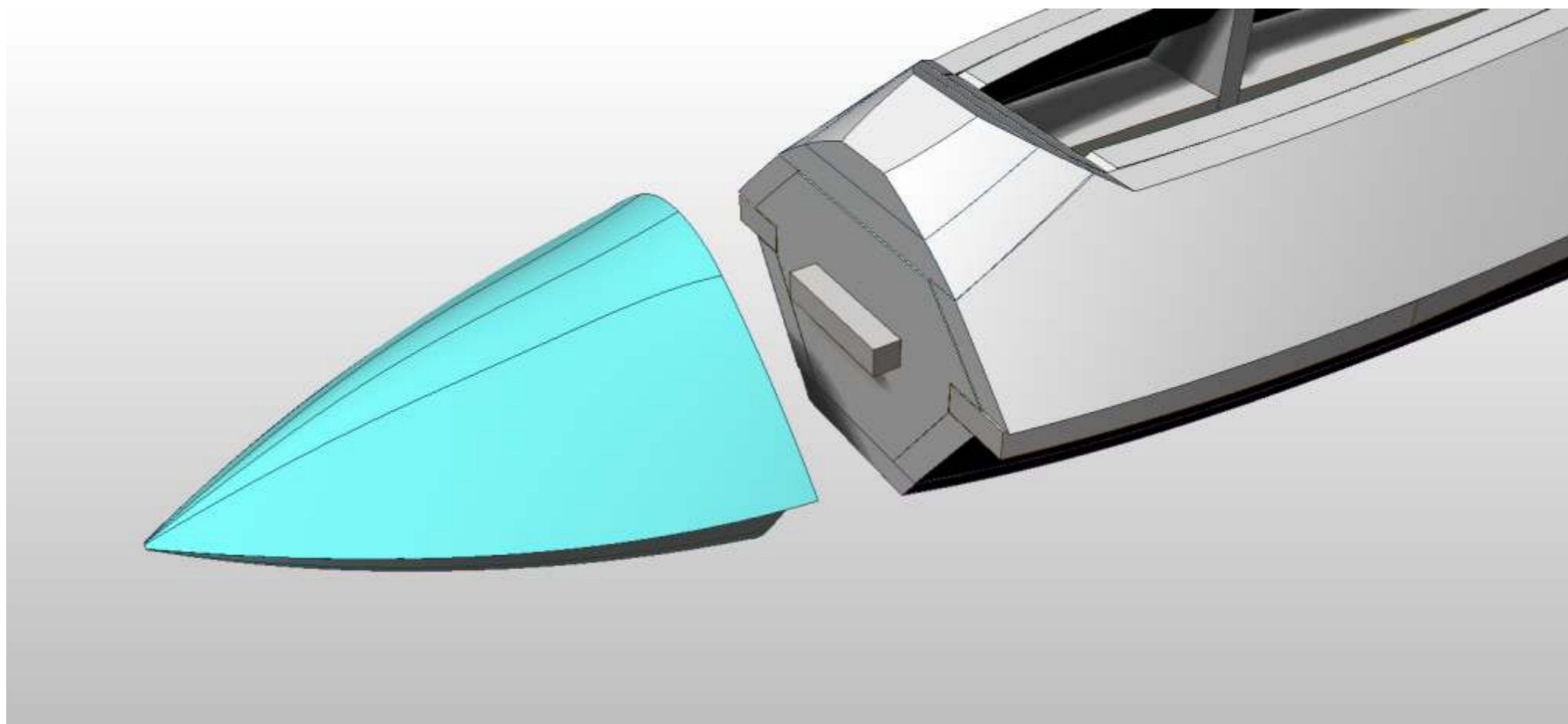

Glue fuselage 1,2 and 3 in place in the slots provided.

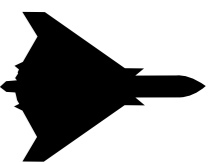



Glue the Upper corner reinforcements to the fuselage side - making sure they are 6mm back from the front of the fuselage to allow for Bulkhead 1 see in next picture.

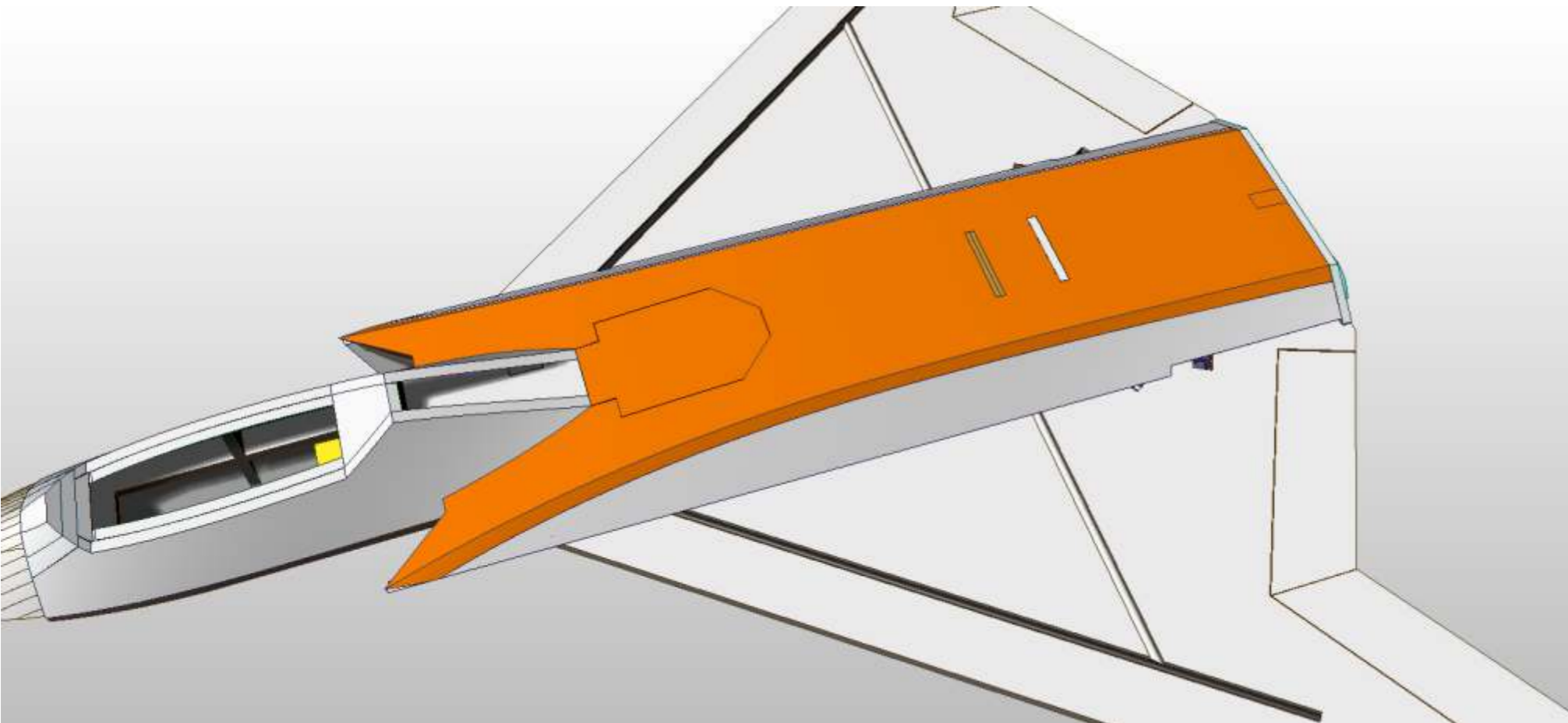

Glue fuselage 1,2 and 3 in place in the slots provided.

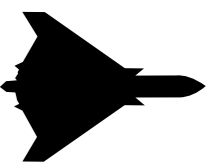



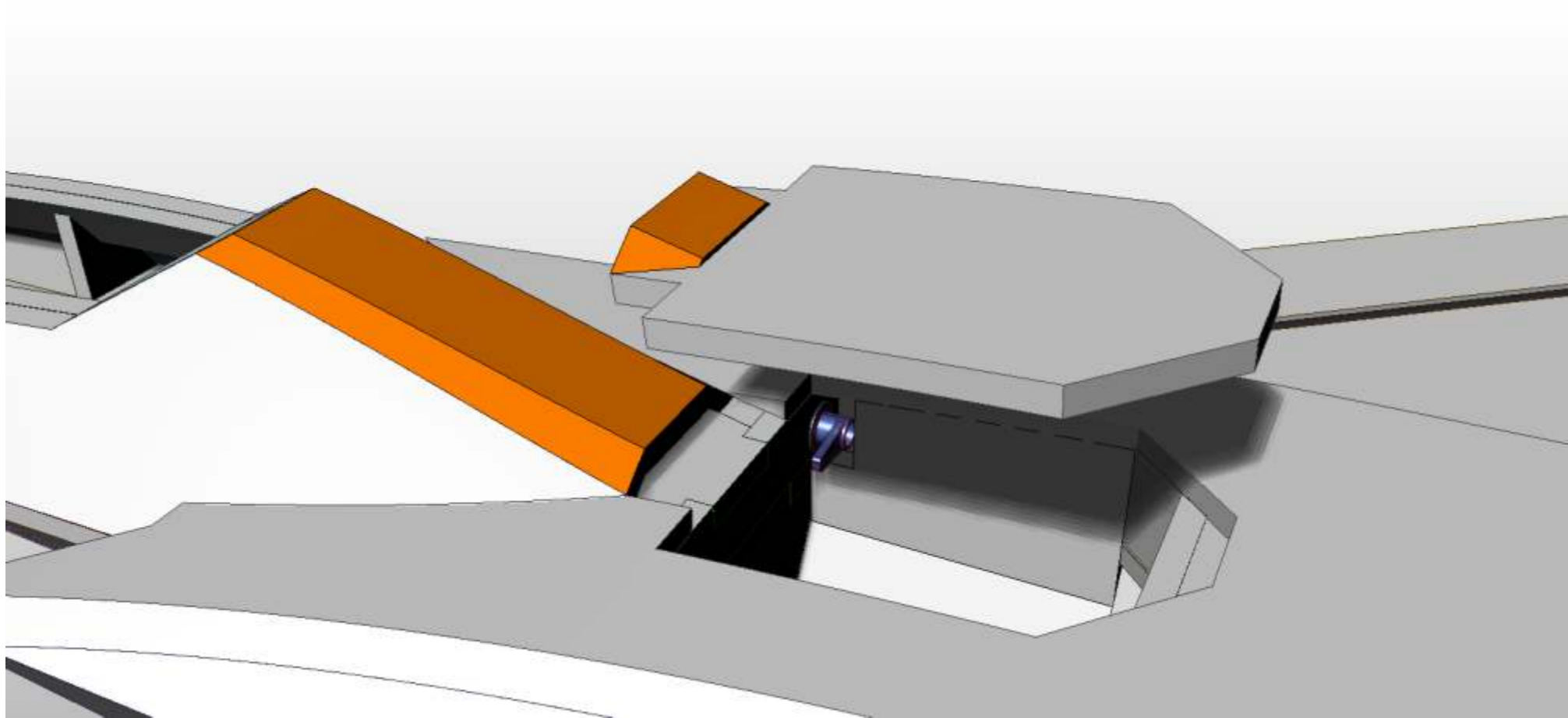

Glue the Upper corner reinforcements to the fuselage side - making sure they are 6mm back from the front of the fuselage to allow for Bulkhead 1 see in next picture.

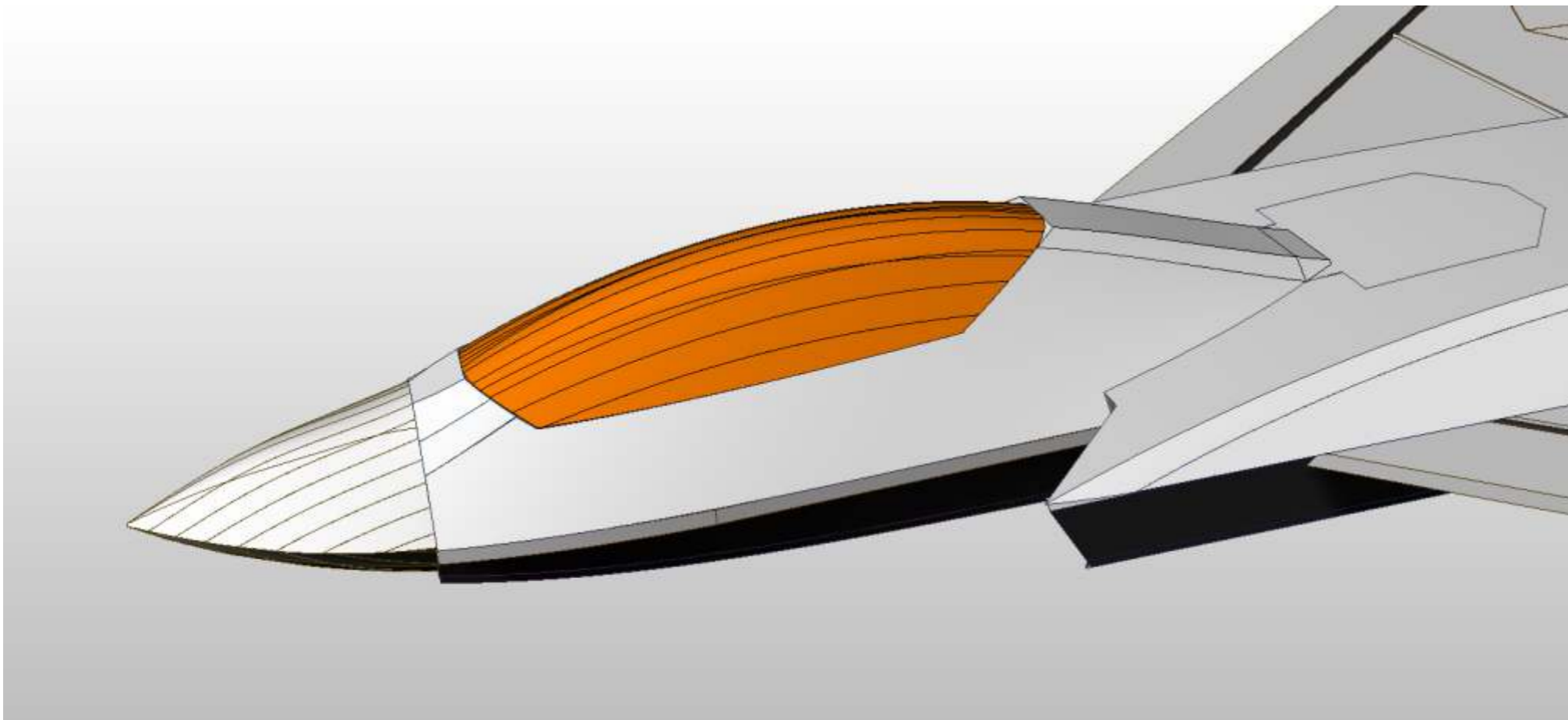

Glue fuselage 1,2 and 3 in place in the slots provided.

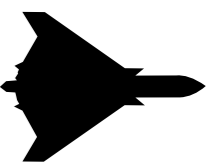

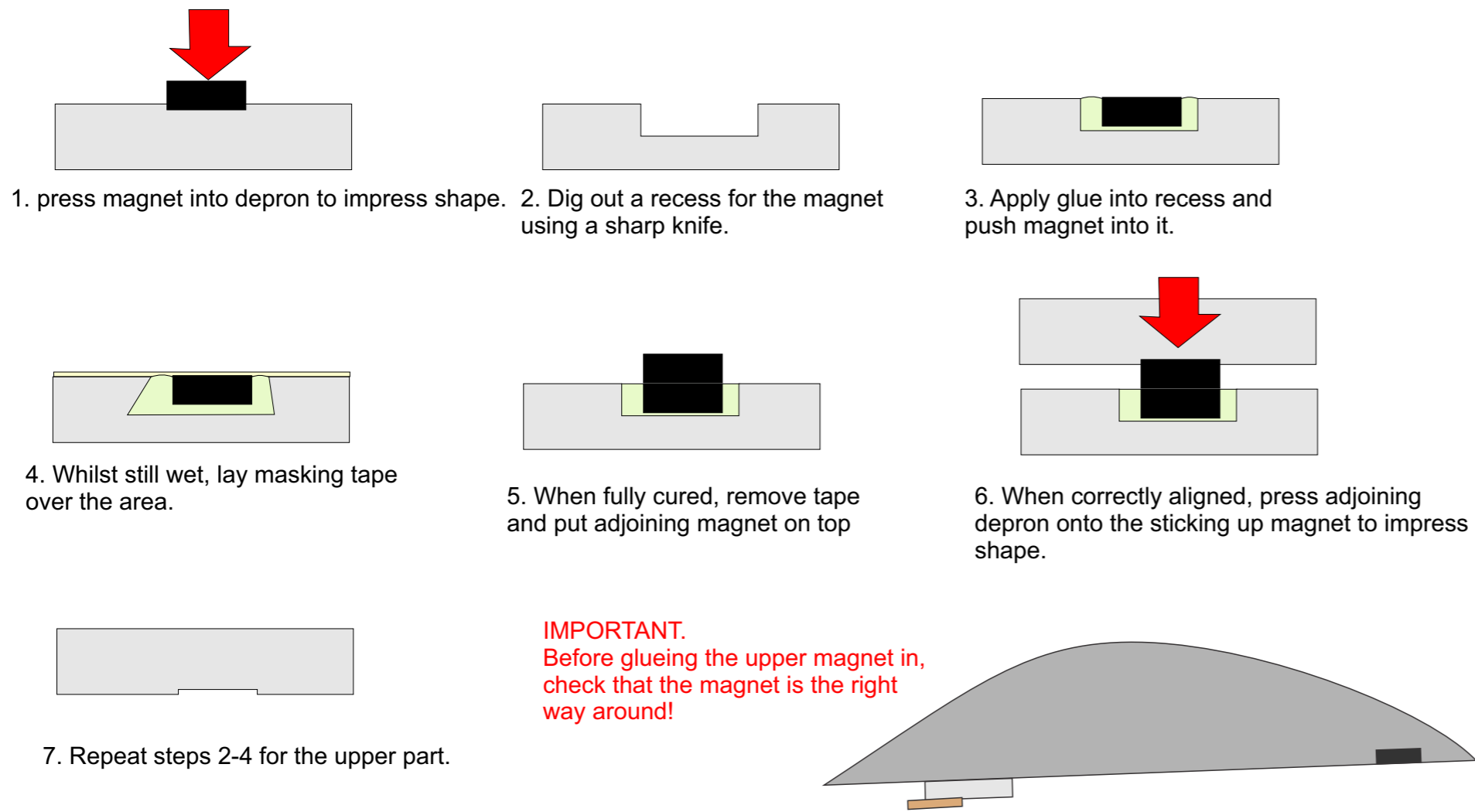
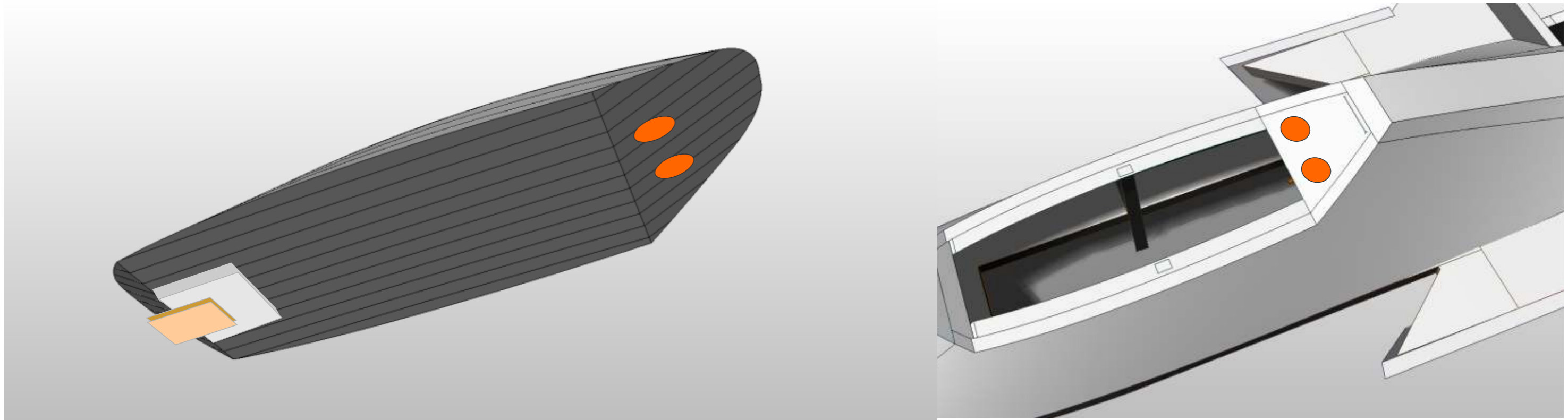

Build a tongue using a piece of scrap depron and 3mm liteply at the front of the canopy.

Attach the magnets to the magnet panel

Epoxy the magnets to rear of the canopy so that the canopy is removable but holds firmly in place when mounted.

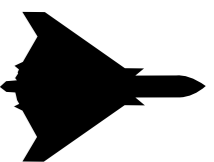

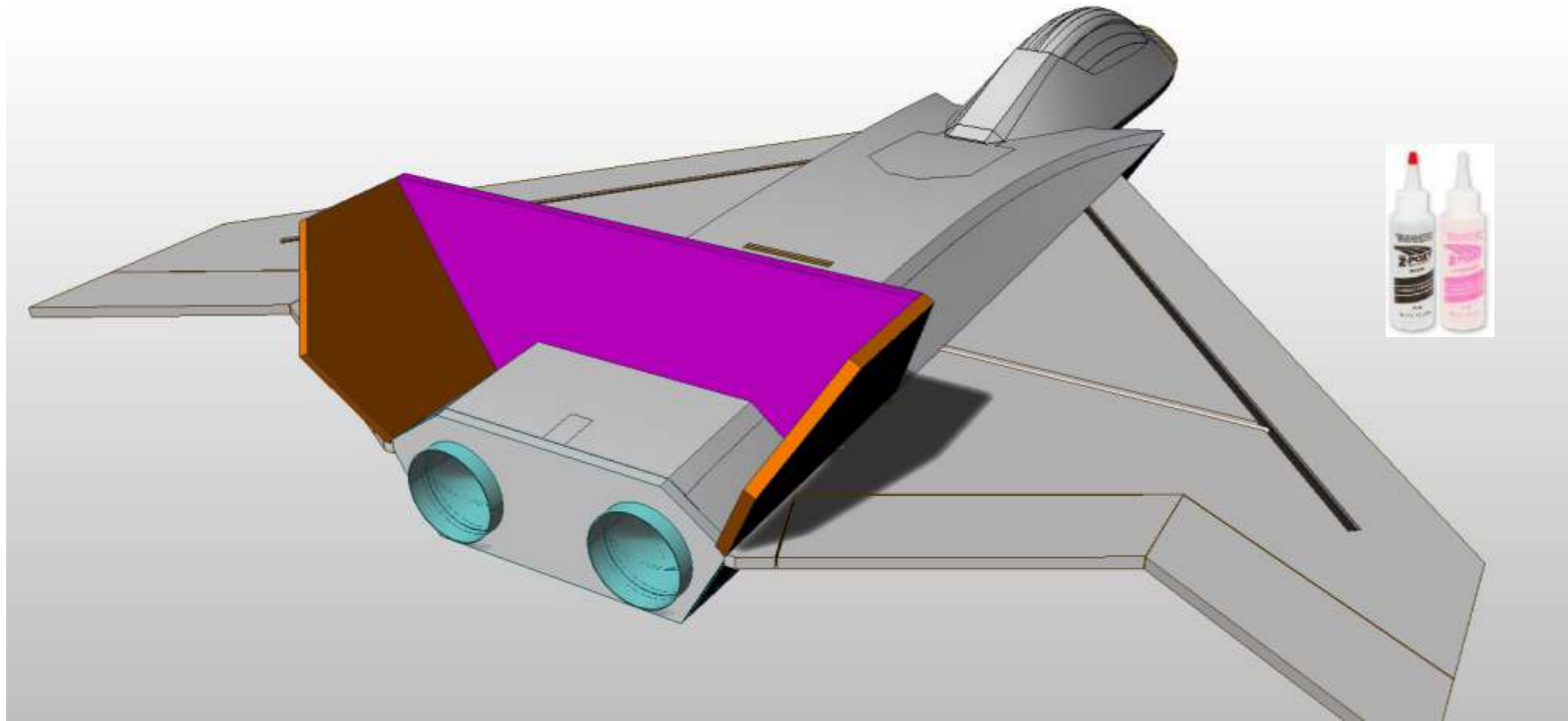

Glue the Upper corner reinforcers to the fuselage side - making sure they are 6mm back from the front of the fuselage to allow for Bulkhead 1 see in next picture.

Glue fuselage 1,2 and 3 in place in the slots provided.

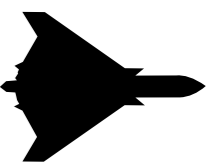

Meteor F.4 Tail style

1.5mm piano wire

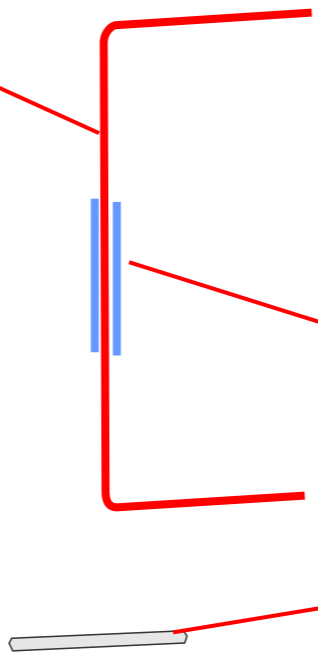

5-Sizes Brass Tube

3mm brass tube



If you are having a working rudder trim away the rudder from the vertical stabiliser and construct the hinge mechanism.

Either way, fit the Servo using hot melt glue along the centreline of the depron (so it sticks out both sides a little) and epoxy the carbon spar in place.

Meteor F.4 Tail style

3mm Depron

3mm Depron

Glue the two 3mm sides onto the vertical stabiliser - again cutting the rudder parts free if you are having a rudder.

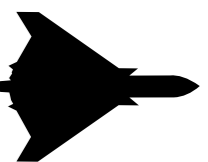

The camouflage version looks particularly menacing!

Use Photo's of the real model to help shape and paint the model

